



3~110kV High Voltage Shunt Capacitor Unit User Manual



Zhejiang Rockwill Energy Technology Co.,Ltd

Preface

The contents of this manual comply with GB 50227-2008 Code for Design of Shunt Capacitor Installations and other relevant national and industrial standards.

Table of Contents

1. Overview	1
1.1 Purpose	1
1.2 Product Model and Its Meaning.....	1
1.3 Applicable Standards	1
2. Operating Environment	2
3. Structure Description.....	2
4. Technical Parameters and Performance	3
5. Equipment Protection (User-Defined Protection Devices).....	8
6. Packaging, Transportation and Storage	9
7. Installation	9
8. Pre-Commissioning Adjustment and Testing.....	8
9. Operation, Inspection and Maintenance	10
10. Safety Regulations.....	11
11. Spare Parts and Documentation.....	11
12. Ordering Information.....	11
13. Typical Primary Schematic Diagram of Capacitor Bank Wiring and Protection.....	12
14. Product Models and Cabinet Dimensions.....	14

1. Overview

1.1 Purpose

The RWTBB series High Voltage Shunt Capacitor Unit (hereinafter referred to as the "Unit") is a capacitive reactive power compensation device. It is primarily used in 3~110kV, 50Hz three-phase AC power systems to improve power factor, regulate network voltage, reduce line losses, enhance power supply quality, and increase the efficiency of power generation and distribution equipment.

1.2 Model Significance

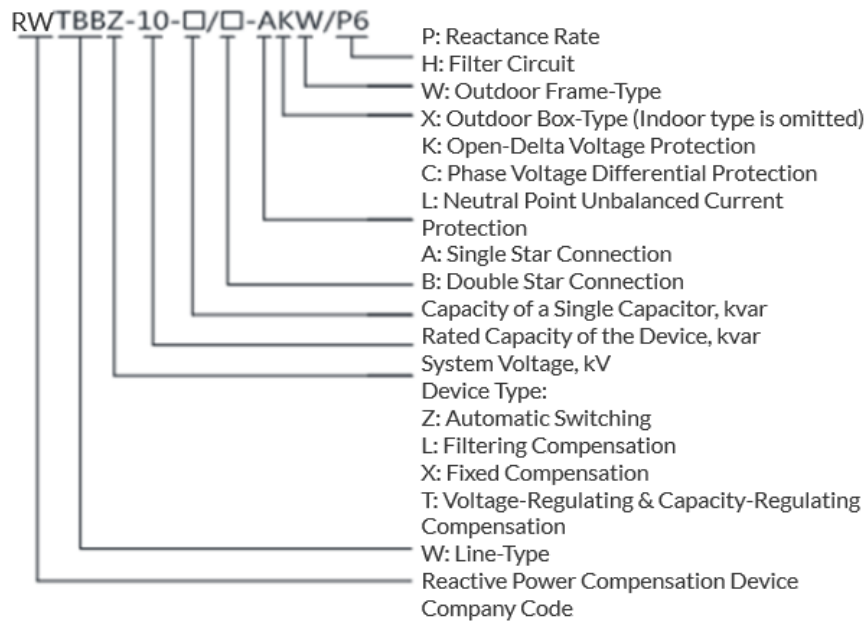

1.3 Executive Standards

GB 50227	Code for Design of Shunt Capacitor Installations
GB/T 11024	Shunt Capacitors for AC Power Systems having a Rated Voltage above 1kV
GB 10229	Reactors
GB 311.1	Insulation Co-ordination for High Voltage Transmission and Distribution Equipment
GB 50060	Code for Design of 3~110kV High Voltage Electrical Installations
JB/T 7111	High Voltage Shunt Capacitor Installations
JB/T 5346	Series Reactors
DL/T 604	Technical Specifications for Ordering High Voltage Shunt Capacitor Installations
DL/T 840	Technical Conditions for Use of High Voltage Shunt Capacitors

Other current national standards

2. Operating Environment

- Installation: Suitable for indoor or outdoor use.
- Altitude: Not exceeding 2000m (custom designs available for high altitude or special regions).
- Ambient Temperature: -40°C to +45°C (special environments negotiable).
- Relative Humidity: Not exceeding 85% (at 20°C);
- Atmospheric Conditions: No harmful gases, vapors, or conductive/explosive dust.
- Vibration: No severe mechanical vibration or jolting.
- Seismic Intensity: Up to Magnitude 8.

3. Structural Introduction

High-voltage shunt capacitor devices are mainly divided into two categories: distributed (frame-type) high-voltage shunt capacitor devices and compact (integrated) high-voltage shunt capacitor devices. Their structures and characteristics are described as follows:

The distributed high-voltage shunt capacitor device consists of disconnectors (earthing switches), discharge coils, zinc oxide arresters, series reactors, high-voltage shunt capacitors, current transformers, expulsion-type fuses, busbars, discharge indicator lamps, and combined cabinets (frames). Cabinet-type devices are generally applied indoors, while combined frame-type devices are suitable for both indoor and outdoor installation. According to user requirements and site conditions, the device can be designed in double-row layout, single-row single-layer, double-layer or triple-layer structures. It features flexible capacity adjustment, convenient installation and maintenance, and low oil storage capacity.

The compact high-voltage shunt capacitor device is mainly composed of disconnectors (earthing switches), discharge coils, zinc oxide arresters, series reactors, integrated compact shunt capacitors, busbars and frames (fences can be equipped as required). Compact high-voltage shunt capacitor devices are mostly used outdoors, with stable operation free from environmental and site restrictions. Integrated capacitors adopt a fully sealed structure and require no maintenance.

Capacity-adjustable high-voltage shunt capacitor devices are further classified into on-load capacity regulation and off-load capacity regulation types. For power systems of 10 kV and below, capacitor devices can realize automatic on-load capacity regulation. By monitoring bus voltage and reactive power parameters, the device controls the switching of vacuum contactors or vacuum switches to complete automatic on-load capacity adjustment, and the capacitor banks can be grouped in accordance with substation operation demands. Off-load capacity regulation includes electric regulation and manual regulation. It realizes off-load capacity switching through different gear positions of built-in electric or manual tap changers of integrated capacitors, or through

combined switching operations of disconnectors.

4. Technical Parameters and Performance

- The primary connection of the device is single-star or double-star. For power systems of 66 kV and below, the neutral point of the capacitor bank is ungrounded, with the same insulation class as the power system; for 110 kV capacitor banks, the neutral point shall be directly and effectively grounded.
- The device shall be capable of continuous operation at 1.10 times the rated voltage, or at a current RMS value of 1.3 times the rated current of the capacitor bank, excluding transient conditions. Since the actual capacitance can reach up to 1.15 CN, the maximum current can reach 1.5 IN. These overcurrent factors take into account the combined effect of harmonics and the overvoltage of 1.10 UN.
- The main supporting electrical components of the device shall comply with the matching relationships specified in the table below.

Nominal System Voltage kV	6			10			20			35			66		110
Rated Device Voltage, kV	6.3			10.5			21			37			69		115.5
Rated Reactance Rate, %	≤5	5	12	≤5	5	12	≤1	5	12	≤5	5	12	5	12	12
Phase Voltage of Capacitor Bank, kV	63δ	66δ	72δ	106δ	11δ	12δ	22δ	23δ	24δ	22	38δ	42δ	42	46	76.21
Rated Terminal Voltage of Reactor, kV	0.018	0.229	0.499	0.030	0.381	0.831	0.127	0.797	1.663	0.11	1.334	2.910	2.52	5.52	9.145
Rated Voltage of Discharge Coil, kV	63δ	66δ	72δ	106δ	11δ	12δ	22δ	23δ	24δ	112	152	122			
Rated Voltage of Arrester, kV	10	10	10	17	17	17	2632	2632	2632	51527	51527	51527	96	96	100
Rated Voltage of Disconnector, kV	10	10	10	10	10	10	20	20	20	35	35	35	66	66	110

- The installed rated capacity of the device is the sum of the rated capacities of all capacitors, and the deviation of its capacitance value shall meet the following requirements:
 - For a capacitor unit or a capacitor bank containing only one unit per phase, the capacitance deviation is -5% ~ +15%;
 - For a capacitor bank with a total capacity of 3 Mvar and below, the capacitance deviation is -5% ~ +10%;
 - For a capacitor bank with a total capacity above 3 Mvar and up to 30 Mvar, the capacitance deviation is 0 ~ +10%;
 - For a capacitor bank with a total capacity above 30 Mvar, the capacitance deviation is 0 ~ +5%.
 - The ratio of the maximum capacitance to the minimum capacitance measured between any two line terminals in a three-phase unit or three-phase capacitor bank shall not exceed 1.08.

4.1 Insulation Level of the Device:

Rated Voltage of the Device, kV	System Voltage (RMS Value), kV		Primary System		Secondary System
			1-minute Power Frequency Withstand Voltage Test (Wet/Dry Test), kV	Lightning Impulse Withstand Voltage Test (1.2~5/50μs Peak Value), kV	1-minute Power Frequency Withstand Voltage Test kV
	Nominal Voltage	Maximum Voltage			
3.15	3	3.5	18/25	40	2
6.3	6	6.9	23/30	60	2
10.5	10	11.5	30/42	75	2
15.7	15	17.5	40/55	105	2
21	20	23	50/65	125	2
37	35	40.5	80/95	185	2
69	66	72.5	140	325	2
115.5	110	126	185/200	450	2

Note: The insulation resistance of the secondary system shall be no less than 2 MΩ.

4.2 The safety clearances (in mm) for the device are specified in the following table:

Applicable Scope	Location	Rated System Voltage (kV)									
		05 (Secondary)	3	6	10	15	20	35	66	110J	110
Between bare conductors of different phases	Indoor	4	75	100	125	150	180	300	550	900	1000
	Outdoor	/	200	200	200	300	300	400	650	1000	1100
Between energized bare conductors and grounded parts	Indoor	15	75	100	125	150	180	300	550	850	950
	Outdoor	/	200	200	200	300	300	400	650	900	1000
Between energized bare conductors and solid doors or solid barriers	Indoor	15	105	130	155	180	210	330	/	/	/
	Outdoor	/	/	/	/	/	/	/	/	/	/
Between energized bare conductors and mesh doors or mesh barriers	Indoor	50	175	200	225	250	280	400	650	950	1050
	Outdoor	/	300	300	300	400	400	500	750	1000	1100
Height of unshielded energized bare conductors above ground	Indoor	/	2500	2500	2500	2500	2500	2600	2850	3150	3250
	Outdoor	/	2700	2700	2700	2800	2800	2900	3100	3400	3500

Note: 110J refers to a power grid with effectively grounded neutral points.

4.3 The performance and parameters of the main auxiliary electrical components of the device

are specified in the following clauses:

When selecting the circuit breaker, its rated voltage shall comply with the rated voltage requirements of the capacitor device; the rated current shall be no less than 1.5 times the rated current of the device; the capacitive current breaking capacity shall be no less than the rated current of the capacitor bank; and the making/breaking capacity shall be no less than the short-circuit capacity of the system. The switching device for the capacitor device is critical; it is required to be free of restrikes, and there are strict requirements for overvoltages caused by three-phase asynchronism, contact bounce, and current chopping. The switch is required to pass the type test for switching capacitive loads, meaning a switch dedicated to capacitors must be used. For switches used with capacitors above 35kV, SF6 switches are recommended as a priority.

The rated voltage of the disconnecter (isolating switch) shall comply with the provisions of Clause 3, and the rated current shall be no less than 1.5 times the rated current of the device. For disconnectors or earthing switches used for grounding, the rated current may be selected as 400A.

4.4 Selection of the reactance rate and type of the series reactor:

Suppression Item	Suppress Closing Inrush	Suppress Harmonics	Suppress Harmonics
Reactance Rate (%)	0.1~1	4.5~5	12~13

Note: When the device is for indoor use, iron-core reactors are recommended (no magnetic leakage, small footprint, low loss), and the reactance rate is generally not less than 6%; for outdoor devices, air-core reactors are generally selected (good linearity, suitable for all-weather conditions). Reactors with other rated values can be separately designed and manufactured according to the buyer's requirements.

4.5 Selection of specifications and parameters for discharge coils:

System Voltage kV	Phase	Reactance Rate%	Rated Primary Voltage kV	Rated Secondary Voltage kV	Rated Secondary Load VA	Rated Discharge Capacity Mvar	3 Units Configurable for 3-Phase Capacitor Capacity kvar
6	1	6	$6.6/\sqrt{3}$	0.1 or $0.1/\sqrt{3}$	100 or 50	1.7~2.5	5100~7500
	1	12	$7.2/\sqrt{3}$	0.1 or $0.1/\sqrt{3}$	100 or 50	1.7~2.5	5100~7500
10	1	6	$11/\sqrt{3}$	0.1 or $0.1/\sqrt{3}$	100 or 50	1.7~4.0	5100~12000
	1	12	$12/\sqrt{3}$	0.1 or $0.1/\sqrt{3}$	100 or 50	1.7~4.0	5100~12000
20	1	1	$22/\sqrt{3}$	0.1 or $0.1/\sqrt{3}$	100 or 50	1.7~4.0	5100~12000
	1	6	$23/\sqrt{3}$	0.1 or $0.1/\sqrt{3}$	100 or 50	1.7~4.0	5100~12000

	1	12	$24/\sqrt{3}$	0.1 或 $0.1/\sqrt{3}$	100 或 50	1.7~4.0	5100~12000
35	1	6	11.5×2	0.1	100	$5 \times 2 \sim 10 \times 2$	30000~60000
	1	12	12×2	0.1	100	$5 \times 2 \sim 10 \times 2$	30000~60000

When the rated discharge capacity of the discharge coil does not exceed the rated capacity of the paralleled capacitor bank, it shall be capable of reducing the residual voltage on the capacitor bank from the peak value of the rated voltage to below 50V within 5 seconds after the capacitor bank is disconnected from the power source. A discharge coil with a secondary winding can also be used for open-delta zero-sequence voltage protection and voltage differential protection.

For discharge coils used in non-standard capacitor banks such as 110kV, they must be selected and matched separately according to the structure and capacity of the device, and their discharge performance must meet the above requirements. Generally, 110kV capacitor devices are equipped with discharge resistors inside the capacitor units. In this case, the device may not be equipped with discharge coils, but the discharge time will be prolonged. Other operations can only be performed 15 minutes after power failure!

4.6 Selection of Zinc Oxide Surge Arresters (MOA)

There are three common wiring methods for zinc oxide surge arresters: three arresters for phase-to-ground protection; four arresters (3+1) for phase-to-phase, pole-to-pole, and neutral-to-ground protection; four arresters (3+1) for phase-to-ground protection and neutral-to-ground protection. According to the requirements of the "Technical Measures for Preventing Accidents of Capacitor Devices" (Gaozhuanwang Mizi [2003] No. 02) issued by the State Grid Corporation of China, the use of the four-arrester wiring method (three star-connected and one connected to the neutral point) is prohibited. Please consider this carefully when selecting! Zinc oxide surge arresters used for capacitor bank protection must be gapless arresters, and the relationship between their 2ms square wave current carrying capacity and the capacitor bank capacity must satisfy the following table:

Nominal System Voltage kV	Rated Terminal Voltage of Capacitor Bank kV	Rated Capacity of Capacitor Device kvar	MOA 2ms Square Wave Current Withstand Capacity A			
			Connection Mode			Neutral-to-Ground
			Type I Connection	Type II Connection	Type III Connection	
				Phase-to-Ground	Neutral-to-Ground	
6	$6.6/\sqrt{3}$	1800		400		
		2400				
		3000		600		600
		3600		800		
		4200				
		4800		1000		800
		5400				

		6000	400	1200	400	1000	
10	11/√3	1800				400	
		2400					
		3000					
		3600					
		4200				600	
		4800					
		5400					
	12/√3	6000					
		7000	400	800	400	800	
		8000					
		8400		1000		1000	
		9600					
		10000		1200			
		12000	600	1500	600	1500	
		35	22	10000	400	400	400
20000	600			800	600	1200	
40000	900			1500	600	1500	
60000	1200			2200	1200	2400	
24	10000		400	400	400	600	
	20000		600	600	600	1000	
	40000		900	1000	900	1500	
	60000		1200	1500	1200	2200	
66	42	20000	500	400	500	800	
		40000	800	800	800	1300	
		60000	1000	1000	1000	1800	

Note: 1. Type I connection mode refers to phase-to-ground protection; Type II connection mode refers to (3+1) inter-phase, inter-pole and neutral-to-ground protection; Type III connection mode refers to (3+1) phase-to-ground and neutral-to-ground protection.

2. When selecting a device with a capacity greater than that of the capacitor bank specified in the table, the current withstand capacity of the zinc oxide arrester must be recalculated.

3. Zinc oxide arresters selected for capacitor banks of other voltage levels must also meet the corresponding current withstand capacity requirements.

4.7 High-voltage Shunt Capacitors

(1)The rated voltage of the high-voltage shunt capacitor shall comply with the matching relationship specified in the following table:

Rated System	Rated Device	K=4.5~5%	K=12~13%

Voltage	Voltage	Phase Voltage of Capacitor	Rated Voltage of Individual	Phase Voltage of Capacitor	Rated Voltage of Individual
kV		kV	kV	kV	kV
3	3.15	$3.4/\sqrt{3}$	$3.4/\sqrt{3}$	$3.6/\sqrt{3}$	$3.6/\sqrt{3}$
6	6.3	$6.6/\sqrt{3}$	$6.6/\sqrt{3}$	$7.2/\sqrt{3}$	$7.2/\sqrt{3}$
10	10.5	$11/\sqrt{3}$	$11/\sqrt{3}$	$12/\sqrt{3}$	$12/\sqrt{3}$
20	21	$23/\sqrt{3}$	$23/\sqrt{3}$	$24/\sqrt{3}$	$24/\sqrt{3}$
35	37	$38.5/\sqrt{3}$ 或 23	$38.5/\sqrt{3}$ 或 11.5	$42/\sqrt{3}$ 或 24	$42/\sqrt{3}$ 或 12
66	69	42	21	46	23
110	115.5	Calculated according to the actual conditions.		Calculated according to the actual conditions.	

Note: The terminal voltage of other non-standard capacitors can also be determined through calculation.

High-voltage shunt capacitors can also be selected with different voltage levels and capacities according to actual needs.

5. Device Protection (Protection devices determined by the user)

- The device shall be equipped with overcurrent protection, and the reliability coefficient of its operating setting value shall be between 1.5 and 2.5.
- The device shall be equipped with instantaneous trip protection.
- The device shall be equipped with overvoltage protection. Its operating voltage setting value shall be set according to $1.1\sim 1.15U_n$, and the setting result shall not exceed $1.2U_c$.
- The device shall be equipped with undervoltage (loss of voltage) protection. Its operating voltage value shall be set at $40\sim 60\%U_n$ (or handled according to the unified setting value of the system), and the undervoltage protection shall not be equipped with an automatic reclosing device.
- The device (capacitor bank) can choose any one or a combination of the following protection methods as the main protection (unbalance protection): neutral point unbalance current protection, open-delta zero-sequence voltage protection, voltage differential protection, and bridge unbalance current protection. This is usually required during ordering and design/manufacturing.

Neutral point unbalance current protection is recommended for double-star wiring and large-capacity capacitor banks.

Open-delta zero-sequence voltage protection is recommended for single-star wiring and small-capacity capacitor banks.

For star-connected capacitor banks with multiple series sections, voltage differential protection is recommended (generally adopted for 35kV capacitor devices).

For high-voltage shunt capacitor devices above 66kV, single-phase bridge connection and unbalance current protection are recommended.

Unlike other electrical equipment, capacitor devices are strictly prohibited from being switched on for testing or operated without connecting the main protection (unbalance protection), unless under special circumstances!

The device is equipped with an anti-maloperation electromagnetic lock and an auxiliary switch interlocked with the circuit breaker to lock the operation of the isolating switch, grounding switch, and circuit breaker. The device meets the "five prevention" requirements.

6. Packaging, Transportation, and Storage

- The device is packaged in separate boxes according to its components.
- During transportation, it must not be inverted or rolled over, and must be protected from rain and moisture.
- During storage, the boxes must not be placed directly on the ground. The warehouse should be well-ventilated, with a relative humidity not exceeding 85%, a temperature range of -25~+40°C, and protection against the intrusion of various harmful gases. It is strictly prohibited to store it in the same warehouse with chemicals, acids, alkalis, batteries, etc.! The storage period should be less than 6 months.

7. Installation

- Upon receiving the device, the user should first conduct a visual inspection to determine if there is any damage to the main components, and then accept the device according to the acceptance items required in the instruction manuals of the main components or according to national standards.
- The installation site of the device should meet the requirements of Item 2 (of the manual). The ambient temperature refers to the air temperature at two-thirds the height of the top-layer capacitor box. If the ambient temperature does not meet the requirements (e.g., higher than 40°C), ventilation and cooling measures must be taken (installation of louvers and exhaust equipment is recommended).
- Overall installation of the device:
 - Arrange and install according to the device structure and capacitor arrangement, following the drawings and relevant regulations. If the capacitors are arranged in a double row, inspection and maintenance passages should be reserved on both the front and rear sides (or as appropriate), with a width of not less than 800mm; if maintenance with tools is considered, the passage width should be not less than 1200mm. The device can also be installed with one side against the wall according to the actual situation.
 - Pre-bury the channel steel and other metal foundation parts (supplied by the user) according to the foundation drawing provided by the manufacturer. The foundation parts also serve as grounding, but they must be reliably connected to the grounding grid.
 - Install and arrange the components according to the "Device General Assembly Drawing" provided by the manufacturer. The components can be connected to the foundation parts by electric welding. The frame-type capacitor device requires the whole structure to be horizontal and vertical, without tilting.

- When installing capacitor units, they should be arranged by phase according to the matching list provided by the manufacturer. They cannot be arbitrarily allocated or arranged to avoid exceeding the capacitance deviation between phases or sections.
- Closed loops formed by metal objects are not allowed around the air-core reactor to avoid increasing losses and affecting the device's performance.
- The electrical and magnetic clearances between the air-core reactor and surrounding objects should meet the requirements. The center-to-center distance between phases of horizontally mounted air-core reactors should not be less than $1.7D$ (D is the outer diameter of the reactor); the distance from the outer edge of the air-core reactor to surrounding metal parts should not only meet the electrical clearance but also meet the magnetic clearance requirement of not less than $1.1D$ (D is the outer diameter of the reactor).
- The connections of the isolating switch, arrester, reactor, discharge coil, capacitor, fuse, and busbar must comply with the requirements of the primary wiring diagram. At the same time, the primary and secondary circuits should be connected according to the primary and secondary drawings and device requirements. The connection wires from the discharge coil to the capacitor bank and busbar need to be flexible connections.
- Installation precautions:
 - All installations of the device must comply with the provisions of relevant installation regulations.
 - The connections of the current-carrying parts must be firm, without virtual connections or looseness.
 - After installation, any damaged paint film should be touched up with paint of the same color, and the bushings, insulators, and device must be wiped clean.

8. Adjustment and Testing Before Operation

- For the adjustment and testing of the switchgear (ordered by the user) before operation, please refer to the relevant requirements in its installation and operation manual.
- Check whether the electromagnetic lock operates sensitively and reliably according to its instruction manual.
- Operate the isolating switch and grounding switch to check if they move flexibly and make good contact. At the same time, check if the contacts of the auxiliary switch are in good, correct, and reliable contact.
- To avoid maloperation of relay protection, the device undergoes capacity balancing adjustment at the factory, and the capacity deviation between phases and differential protection sections has been controlled within the allowable range. It should be checked whether the capacitors are installed according to the arrangement in the matching list.
- After completing the routine tests, determine the operation plan according to the power grid operation conditions, and then the power can be turned on for trial operation.
- Before continuous operation, a protection transmission test must be performed to verify whether the protection device parameter settings and actions are accurate. If the protection action is abnormal, check whether the protection device, wiring, and parameters are normal. Continue the test only after troubleshooting. If the protection action is correct, after checking all primary and secondary equipment, operate according to regulations to power on for trial operation. If there is no abnormality after 24 hours of trial operation, it can be put into normal continuous operation.

9. Operation, Patrol, and Maintenance

- On-duty personnel should keep detailed records of the operation status.
- The appearance of each component of the device can be monitored from outside the fence or viewing window. It is recommended to conduct patrols daily. The surfaces of bushings and the enclosures of electrical

appliances should be cleaned at least once every three months to prevent the accumulation of dust and dirt that could cause accidents.

- Check the load and capacity of the device using the ammeter and reactive power meter.
- Check whether the fault protection has operated by observing the action indication of the signal relay. If there is a problem, it should be resolved in a timely manner.
- During power-off maintenance, check whether electrical connections are loose. If any issues are found, handle them promptly.
- Regular preventive inspections should be conducted on major electrical components, such as checking the capacitance value of capacitors, the insulation resistance of capacitors, reactors, and instrument transformers, and oil levels.
- For the operation and monitoring of switchgear and switching devices, please refer to their instruction manuals.

10. Safety Regulations

- Before putting the device into operation, it is mandatory to check whether the interlock positions of the circuit breaker, isolating switch, and grounding switch are correct, and whether the interlocks are accurate and reliable. The cabinet door must be closed properly. Opening the cabinet door during operation is strictly prohibited!
- The grounding points of the switchgear, reactor, capacitor cabinet, secondary terminal room (box), and cable termination box must be well protected and maintain good contact.
- Check whether the parameter settings of the protection device are correct, whether the wiring is correct and reliable, and whether the protection pressure plate is in the correct position. For protection devices with automatic reclosing set up, the protection pressure plate should be in the withdrawn state. Automatic reclosing devices are strictly prohibited for high-voltage shunt capacitor devices!
- Unlike most electrical appliances, shunt capacitors operate continuously once put into operation, and their load only changes with voltage and frequency variations. The voltage across capacitor terminals during light load conditions may be particularly high. At this time, to prevent overvoltage of capacitor units and excessive voltage rise in the network, part or all of the capacitors should be switched off. Capacitors are only allowed to operate under the simultaneous conditions of maximum allowable voltage and maximum ambient temperature in emergencies, and only for a short duration.
- During maintenance, the device must be powered off for 10 minutes, the grounding switch must be closed, the grounding wire connected, and safety measures implemented before maintenance personnel can enter for maintenance.
- For devices with discharge coils, the minimum time for manual reclosing cannot be less than 30 seconds. For devices without discharge coils but with internal discharge resistors in the capacitors, wait for 10 minutes after power failure, then close the grounding knife switch for supplementary discharge, and then open the grounding knife switch before reclosing can be performed.

11. Spare Parts and Documentation

- The following spare parts can be provided when the device leaves the factory according to user needs:
- High-voltage shunt capacitors (provided upon contract requirement);
- Fuses (provided upon user request);
- Indicator lights (provided upon user request);
- The following documents are attached when the device leaves the factory:
- Installation and operation manual for high-voltage shunt capacitor devices;

- Test report for high-voltage shunt capacitor devices;
- Operation manual for shunt capacitors;
- Operation manual for reactors;
- Operation manuals for each major component;
- Capacitor device matching list (provided upon request);
- Drawings provided with the device:
- General assembly drawing of the high-voltage shunt capacitor device;
- Primary and secondary schematic diagrams of the high-voltage shunt capacitor device;
- Plan foundation drawing of the high-voltage shunt capacitor device (provided upon request);

12. Notes for Ordering

- When ordering, please specify the capacity, model, and quantity of the device, and provide data such as the reactance rate of the series reactor, incoming line method, and room (or site) dimensions;
- In some networks, there is a large difference between the network operating voltage and the nominal voltage. The buyer should provide detailed information so that the manufacturer can allow for appropriate margins.
- If a separate design is required based on system conditions, the primary system diagram of the user's power grid and its parameters should be provided.
- When selecting a model, priority is given to the data provided by the buyer, and optimization can be performed based on the actual situation. If there are special requirements, they can be negotiated separately with the supplier.

13. Primary Schematic Diagram of Typical Capacitor Device Wiring and Protection

(1) Primary Schematic Diagram of Open-Delta Protection for Single-Star Connection

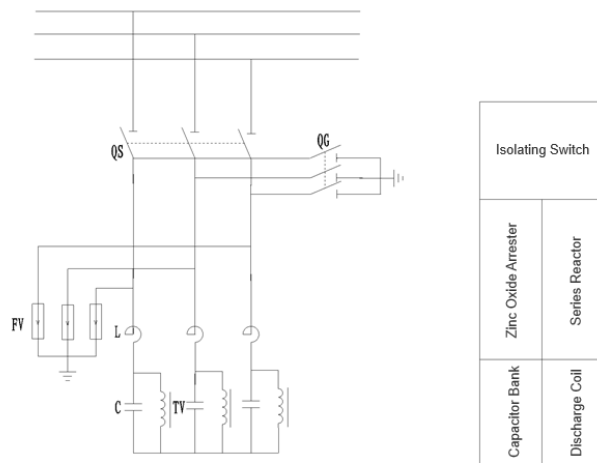

Single Star Connection Open Delta Voltage Protection

(2) Primary Schematic Diagram of Neutral Point Unbalance Current Protection for Double-Star Connection

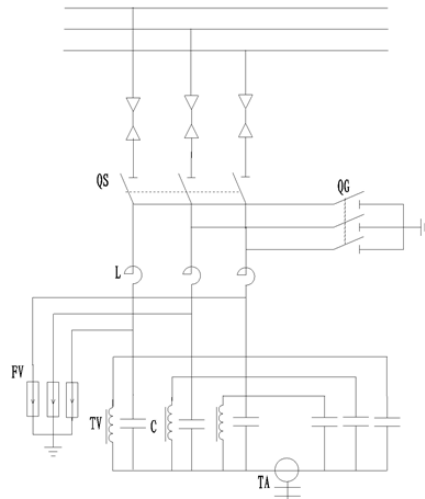

Isolating Switch	
Zinc Oxide Arrester	Series Reactor
Capacitor Bank	Discharge Coil
	Current Transformer

Neutral Point Unbalance Current Protection for Double-Star Connection

(3) Primary Schematic Diagram of Voltage Differential Protection for Single-Star Connection

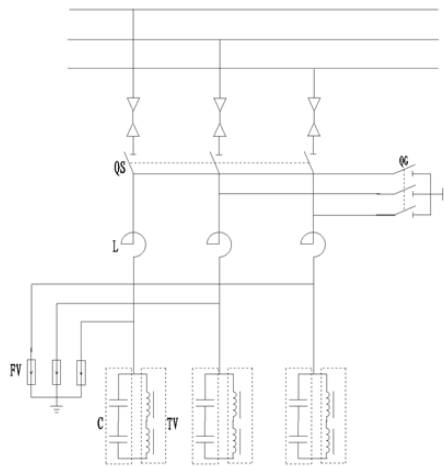

Isolating Switch	
Series Reactor	
Zinc Oxide Arrester	Capacitor Bank
	Discharge Coil

Single-star connection voltage differential protection

(4) Primary Schematic Diagram of Unbalance Current Protection for Single-Star Bridge Connection

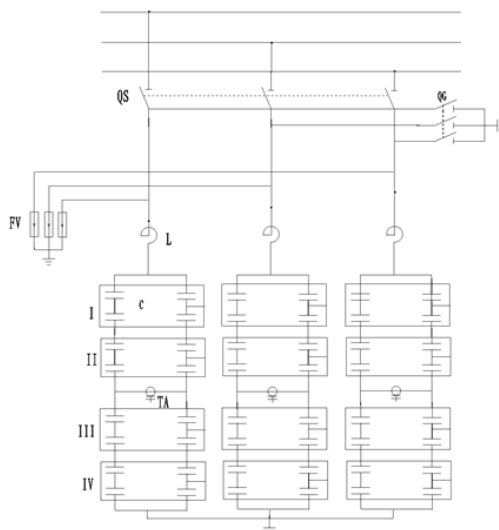

Isolating Switch	
Zinc Oxide Arrester	Series Reactor
Capacitor Bank	
Current Transformer	
Capacitor Bank	

Bridge Connection Unbalance Current Protection

14. Product Model and Cabinet Dimensions

No.	Equipment Name	Model & Specification	Unit	Quantity	Remarks
1	HV Outdoor Fixed Compensation Set	RWTBBX-10-300/100var-AKW/P6	Set	1	4000*2000*3000mm
2	HV Outdoor Fixed Compensation Set	RWTBBX-10-400/134var-AKW/P6	Set	1	4000*2000*3000mm
3	HV Outdoor Fixed Compensation Set	RWTBBX-10-450/150var-AKW/P6	Set	1	4000*2000*3000mm
4	HV Outdoor Fixed Compensation Set	RWTBBX-10-500/167var-AKW/P6	Set	1	4000*2000*3000mm
5	HV Outdoor Fixed Compensation Set	RWTBBX-10-600/200var-AKW/P6	Set	1	4000*2000*3000mm
6	HV Outdoor Fixed Compensation Set	RWTBBX-10-700/234var-AKW/P6	Set	1	4000*2000*3000mm
7	HV Outdoor Fixed Compensation Set	RWTBBX-10-750/250var-AKW/P6	Set	1	4000*2000*3000mm
8	HV Outdoor Fixed Compensation Set	RWTBBX-10-800/267var-AKW/P6	Set	1	4000*2000*3000mm
9	HV Outdoor Fixed Compensation Set	RWTBBX-10-900/300var-AKW/P6	Set	1	4000*2000*3000mm
10	HV Outdoor Fixed Compensation Set	RWTBBX-10-1000/334var-AKW/P6	Set	1	4000*2000*3000mm
11	HV Outdoor Fixed Compensation Set	RWTBBX-10-1200/400var-AKW/P6	Set	1	4000*2000*3000mm
12	HV Outdoor Fixed Compensation Set	RWTBBX-10-1400/234var-AKW/P6	Set	1	4000*2000*3000mm
13	HV Outdoor Fixed Compensation Set	RWTBBX-10-1500/250var-AKW/P6	Set	1	4000*2000*3000mm
14	HV Outdoor Fixed Compensation Set	RWTBBX-10-1600/267var-AKW/P6	Set	1	4000*2000*3000mm
15	HV Outdoor Fixed Compensation Set	RWTBBX-10-1800/300var-AKW/P6	Set	1	4000*2000*3000mm
16	HV Outdoor Fixed Compensation Set	RWTBBX-10-2000/334var-AKW/P6	Set	1	4000*2000*3000mm
17	HV Outdoor Fixed Compensation Set	RWTBBX-10-2100/350var-AKW/P6	Set	1	4000*2000*3000mm
18	HV Outdoor Fixed Compensation Set	RWTBBX-10-2400/400var-AKW/P6	Set	1	4000*2000*3000mm
19	HV Outdoor Fixed Compensation Set	RWTBBX-10-2500/417var-AKW/P6	Set	1	4000*2000*3000mm
20	HV Outdoor Fixed Compensation Set	RWTBBX-10-2700/450var-AKW/P6	Set	1	4000*2000*3000mm

	Compensation Set	P6			
21	HV Outdoor Fixed Compensation Set	RWTBBX-10-3000/500var-AKW/P6	Set	1	4000*2000*3000mm
22	HV Outdoor Fixed Compensation Set	RWTBBX-10-3200/267var-AKW/P6	Set	1	5200*2000*3000mm
23	HV Outdoor Fixed Compensation Set	RWTBBX-10-3600/300var-AKW/P6	Set	1	5200*2000*3000mm
24	HV Outdoor Fixed Compensation Set	RWTBBX-10-4000/334var-AKW/P6	Set	1	5200*2000*3000mm
25	HV Outdoor Fixed Compensation Set	RWTBBX-10-4200/350var-AKW/P6	Set	1	5200*2000*3000mm
26	HV Outdoor Fixed Compensation Set	RWTBBX-10-4500/375var-AKW/P6	Set	1	5200*2000*3000mm
27	HV Outdoor Fixed Compensation Set	RWTBBX-10-4800/400var-AKW/P6	Set	1	5200*2000*3000mm
28	HV Outdoor Fixed Compensation Set	RWTBBX-10-5000/334var-AKW/P6	Set	1	5200*2000*3000mm
29	HV Outdoor Fixed Compensation Set	RWTBBX-10-6000/334var-AKW/P6	Set	1	6500*2000*3000mm
30	HV Outdoor Fixed Compensation Set	RWTBBX-10-6000/334var-BLW/P6	Set	1	6500*2000*3000mm
31	HV Outdoor Fixed Compensation Set	RWTBBX-10-7200/300var-BLW/P6	Set	1	6700*2000*3200mm
32	HV Outdoor Fixed Compensation Set	RWTBBX-10-8000/334var-BLW/P6	Set	1	6700*2000*3200mm
33	HV Outdoor Fixed Compensation Set	RWTBBX-10-8400/400var-BLW/P6	Set	1	6700*2000*3200mm
34	HV Outdoor Fixed Compensation Set	RWTBBX-10-9000/375var-BLW/P6	Set	1	6700*2000*3200mm
35	HV Outdoor Fixed Compensation Set	RWTBBX-10-9600/400var-BLW/P6	Set	1	6700*2000*3200mm
36	HV Outdoor Fixed Compensation Set	RWTBBX-10-10000/334var-BLW/P6	Set	1	6950*2000*3200mm
37	HV Outdoor Fixed Compensation Set	RWTBBX-10-12000/400var-BLW/P6	Set	1	6950*2000*3200mm
	HV Outdoor Fixed Compensation Set				
No.	HV Outdoor Fixed Compensation Set	Model & Specification	Unit	Quantity	Remarks
1	HV Outdoor Fixed Compensation Set	RWTBBX-10-300/100var-AKW/P12	Set	1	4000*2000*3000mm
2	HV Outdoor Fixed Compensation Set	RWTBBX-10-400/134var-AKW/P12	Set	1	4000*2000*3000mm

	Compensation Set	12			
3	HV Outdoor Fixed Compensation Set	RWTBBX-10-450/150var-AKW/P12	Set	1	4000*2000*3000mm
4	HV Outdoor Fixed Compensation Set	RWTBBX-10-500/167var-AKW/P12	Set	1	4000*2000*3000mm
5	HV Outdoor Fixed Compensation Set	RWTBBX-10-600/200var-AKW/P12	Set	1	4000*2000*3000mm
6	HV Outdoor Fixed Compensation Set	RWTBBX-10-700/234var-AKW/P12	Set	1	4000*2000*3000mm
7	HV Outdoor Fixed Compensation Set	RWTBBX-10-750/250var-AKW/P12	Set	1	4000*2000*3000mm
9	HV Outdoor Fixed Compensation Set	RWTBBX-10-900/300var-AKW/P12	Set	1	4000*2000*3000mm
10	HV Outdoor Fixed Compensation Set	RWTBBX-10-1000/334var-AKW/P12	Set	1	4000*2000*3000mm
11	HV Outdoor Fixed Compensation Set	RWTBBX-10-1200/400var-AKW/P12	Set	1	4000*2000*3000mm
12	HV Outdoor Fixed Compensation Set	RWTBBX-10-1400/234var-AKW/P12	Set	1	4000*2000*3000mm
13	HV Outdoor Fixed Compensation Set	RWTBBX-10-1500/250var-AKW/P12	Set	1	4000*2000*3000mm
14	HV Outdoor Fixed Compensation Set	RWTBBX-10-1600/267var-AKW/P12	Set	1	4000*2000*3000mm
15	HV Outdoor Fixed Compensation Set	RWTBBX-10-1800/300var-AKW/P12	Set	1	4000*2000*3000mm
16	HV Outdoor Fixed Compensation Set	RWTBBX-10-2000/334var-AKW/P12	Set	1	4000*2000*3000mm
17	HV Outdoor Fixed Compensation Set	RWTBBX-10-2100/350var-AKW/P12	Set	1	4000*2000*3000mm
18	HV Outdoor Fixed Compensation Set	RWTBBX-10-2400/400var-AKW/P12	Set	1	4000*2000*3000mm
19	HV Outdoor Fixed Compensation Set	RWTBBX-10-2500/417var-AKW/P12	Set	1	4000*2000*3000mm
20	HV Outdoor Fixed Compensation Set	RWTBBX-10-2700/450var-AKW/P12	Set	1	4000*2000*3000mm
21	HV Outdoor Fixed Compensation Set	RWTBBX-10-3000/500var-AKW/P12	Set	1	4000*2000*3000mm
22	HV Outdoor Fixed Compensation Set	RWTBBX-10-3200/267var-AKW/P12	Set	1	5200*2000*3000mm
23	HV Outdoor Fixed Compensation Set	RWTBBX-10-3600/300var-AKW/P12	Set	1	5200*2000*3000mm
24	HV Outdoor Fixed	RWTBBX-10-4000/334var-AKW/P12	Set	1	5200*2000*3000mm

	Compensation Set	P12			
25	HV Outdoor Fixed Compensation Set	RWTBBX-10-4200/350var-AKW/P12	Set	1	5200*2000*3000mm
26	HV Outdoor Fixed Compensation Set	RWTBBX-10-4500/375var-AKW/P12	Set	1	5200*2000*3000mm
27	HV Outdoor Fixed Compensation Set	RWTBBX-10-4800/400var-AKW/P12	Set	1	5200*2000*3000mm
28	HV Outdoor Fixed Compensation Set	RWTBBX-10-5000/334var-AKW/P12	Set	1	5200*2000*3000mm
29	HV Outdoor Fixed Compensation Set	RWTBBX-10-6000/334var-AKW/P12	Set	1	6500*2000*3000mm
30	HV Outdoor Fixed Compensation Set	RWTBBX-10-6000/334var-BLW/P12	Set	1	6500*2000*3000mm
31	HV Outdoor Fixed Compensation Set	RWTBBX-10-7200/300var-BLW/P12	Set	1	6700*2000*3200mm
32	HV Outdoor Fixed Compensation Set	RWTBBX-10-8000/334var-BLW/P12	Set	1	6700*2000*3200mm
33	HV Outdoor Fixed Compensation Set	RWTBBX-10-8400/400var-BLW/P12	Set	1	6700*2000*3200mm
34	HV Outdoor Fixed Compensation Set	RWTBBX-10-9000/375var-BLW/P12	Set	1	6700*2000*3200mm
35	HV Outdoor Fixed Compensation Set	RWTBBX-10-9600/400var-BLW/P12	Set	1	6700*2000*3200mm
36	HV Outdoor Fixed Compensation Set	RWTBBX-10-10000/334var-BLW/P12	Set	1	6950*2000*3200mm
37	HV Outdoor Fixed Compensation Set	RWTBBX-10-12000/400var-BLW/P12	Set	1	6950*2000*3200mm