



RWCME-I Series Parallel Capacitor On-line Early Warning & Protection Device





Foreword

Please read this chapter carefully before using the product!

This chapter describes safety precautions before using the product. All contents in this chapter must be fully read and understood during installation and operation. We shall not be liable for any damage caused by improper operation if the warnings in this manual are ignored.

Before any operation on this device, relevant professionals must carefully read this manual and be familiar with the operation contents.

When electrical equipment is in operation, some components of these devices may carry high voltage. Incorrect operation may cause severe personal injury or equipment damage.

Only qualified professional staff are allowed to work on or near the device. Staff must be familiar with the precautions, workflows and safety regulations in this manual.

Special attention: general working rules for live high-voltage equipment must be observed. Non-compliance may cause serious personal injury or equipment damage. Never open the secondary circuit of the current transformer connected to the device when the primary system is live. An open circuit in this loop may generate extremely dangerous high voltage.

- Exposed Terminals

Do not touch exposed terminals when the device is live, as dangerous high voltage may be present.

- Residual Voltage

Dangerous voltage may still exist in the DC circuit after the device power is turned off. These voltages disappear after several seconds.

- Grounding



RWCME-I Shunt Capacitor Online Early Warning and Protection Device

The grounding terminal of the device must be reliably grounded.

Operating Environment

The device shall only operate in the atmospheric environment specified in the technical parameters, and the operating environment shall be free from abnormal vibration.

- Ratings

Before connecting the AC voltage/current circuit or DC power circuit, confirm that they comply with the rated parameters of the device.

- Printed Circuit Board

Do not insert or remove the printed circuit board while the device is live; otherwise, the device may malfunction.

- External Circuit

When connecting the output contacts of the device to an external circuit, carefully check the external power supply voltage to prevent overheating of the connected circuit.

- Connecting Cables

Handle connecting cables carefully to avoid excessive mechanical stress.



Table of Content

Foreword.....	- 2 -
Chapter 1 Overview	- 6 -
Application Scope.....	- 6 -
Function Configuration	- 7 -
1.2.1 Protection Functions	- 7 -
1.2.2 Measurement & Control Inputs	- 8 -
1.2.3 Measurement & Control Outputs	- 8 -
1.3 Performance Features.....	- 8 -
1.4 Ordering Instructions	- 9 -
1.5 Product Standards.....	- 9 -
Chapter 2 Technical Parameters.....	- 9 -
2.1 Electrical Parameters.....	- 9 -
2.2 Environmental Condition Parameters	- 10 -
2.3 Communication Ports.....	- 10 -
2.3.1 RS-485 Interface	- 10 -
2.3.2 Ethernet Interface	- 11 -
Chapter 3 Working Principle	- 11 -
3.1 Overview	- 11 -
3.2 Capacitor Fault Early Warning.....	- 15 -
3.3 Reactor Fault Early Warning.....	- 18 -
3.4 Discharge Coil Fault Early Warning.....	- 19 -
3.5 Fire Early Warning	- 19 -
3.6 Protection Functions of Capacitor Device.....	- 19 -
3.7 Fault Location Function of Capacitor Device.....	- 20 -
Chapter 4 System Composition.....	- 20 -
4.1 Device Panel Layout	- 20 -
4.2 Structure and Installation.....	- 21 -
4.2.1 Mechanical Dimensions	- 21 -
4.3 Device Terminal Definition	- 22 -
4.4 Device Terminal Wiring Instruction.....	- 22 -
4.5 Device Interface Wiring Diagram	- 25 -
Chapter 5 Human-Machine Interface Description	- 26 -
5.1 System Monitoring Interface.....	- 26 -
5.2 Harmonic Measurement Interface.....	- 28 -
5.3 Impedance Measurement Interface.....	- 28 -
5.4 Historical Data Interface.....	- 29 -
5.5 Alarm Record Interface	- 29 -
5.6 Operating Parameter Interface	- 29 -
5.7 Protection Setting Interface	- 31 -



RWCME-I Shunt Capacitor Online Early Warning and Protection Device

5.7 System Settings Interface.....	- 40 -
Chapter 6 Device Power-Up and Commissioning.....	- 41 -
6.1 Device Energization and Status Check.....	- 41 -
6.2 Parameter Setting	- 41 -
6.3 Commissioning Purpose.....	- 41 -
Chapter 7 After-Sales Commitment.....	- 42 -
7.1 Product Quality Commitment	- 42 -
7.2 Product Price Commitment.....	- 42 -
7.3 Delivery Schedule Commitment.....	- 43 -
7.4 After-Sales Service Commitment	- 43 -



Chapter 1 Overview

Application Scope

Reactive power compensation equipment is essential for enhancing power system stability, improving power quality, and minimizing grid losses. Power capacitors, as the primary devices for reactive power compensation, are widely deployed in power systems, with shunt capacitors being the most common type used for this purpose. These capacitors effectively optimize power system configuration and power quality, and their reliable operation is critical to overall power system safety.

Due to the high electric field strength they are subjected to during operation, as well as various system overvoltages, capacitors are prone to accelerated aging. In long-term service, they frequently experience failures, and in severe cases, explosions or fires that endanger personnel safety, creating significant risks to both system operation and staff. The conventional preventive maintenance approach introduces unnecessary outages and maintenance activities; repeated disassembly and reassembly can lead to premature equipment degradation, while minor incipient faults often go undetected, leaving substantial safety hazards for capacitor banks.

Currently, substations house large quantities of capacitors, which are typically protected by unbalance monitoring schemes applied to entire banks (inter-phase or inter-section unbalance protection). When one or more capacitors suffer partial or total failure, the unbalance protection operates to trip the entire bank, requiring subsequent offline testing of individual units to locate the faulty capacitor. This method is inherently reactive: it only identifies the affected bank, not the specific failed unit, necessitating time-consuming and labor-intensive individual inspections. Given the high reactive power rating of each capacitor, the extent of damage cannot be accurately assessed during operation, leading to extensive maintenance work, significant manpower requirements, and prolonged outages that disrupt power system operation and result in economic losses for utilities.

The RWCME-I Shunt Capacitor Online Early Warning and Protection Device is designed for the protection of shunt capacitor banks, online power quality monitoring, and early warning protection for capacitors, reactors, and discharge coils in non-effectively grounded or low-resistance grounded systems with voltage ratings up to 110 kV. This online monitoring system continuously assesses the operating condition of shunt capacitor banks. It provides timely early warning and tripping protection in the event of parameter deviations or faults in capacitors



RWCME-I Shunt Capacitor Online Early Warning and Protection Device
or reactors, and supports fault analysis and location.

Function Configuration

1.2.1 Protection Functions

RWCME-I provides protection functions including (the following are all three-phase protections, which can be located to each phase):

- Three-phase undervoltage protection
- Open-delta voltage unbalanced protection
- Double-star neutral unbalanced current protection
- Phase voltage differential unbalanced protection
- Bridge differential current protection
- Instantaneous overcurrent protection
- Time-limited instantaneous overcurrent protection
- Overcurrent protection
- Reactor 3rd/5th harmonic current over-limit early warning
- Harmonic voltage over-limit early warning
- Capacitance lower-deviation early warning
- Capacitance upper-deviation early warning
- Capacitor dielectric loss over-limit early warning
- Discharge coil fault early warning protection
- Reactance lower-deviation early warning
- Reactance upper-deviation early warning
- Reactor inter-turn short-circuit early warning



- Resonance frequency over-limit early warning
- Ultra-high temperature early warning protection

It also includes the following abnormal alarm functions:

- General fault signal.
- Fire alarm.
- Control circuit break alarm.

1.2.2 Measurement & Control Inputs

8 remote signal inputs are provided, including capacitor bank switching status, disconnecter status, earthing switch status, cabinet/grid door status, external early warning reset input, external blocking reset input, external blocking status, and fire alarm status. The device also supports 3 custom remote signal inputs (up to 20 after expansion).

1.2.3 Measurement & Control Outputs

7 measurement & control outputs are provided, including capacitor bank closing, opening, protection tripping, early warning, alarm, blocking, and fan control. The device also supports 3 custom measurement & control outputs (up to 20 after expansion).

1.3 Performance Features

- High-performance general-purpose hardware, real-time calculation

It adopts a 32-bit high-performance DSP+ARM dual-core processor. The DSP core completes protection algorithms, output logic, and background communication, while the ARM core realizes event recording, historical data storage, human-machine interface (HMI), and other functions. The high-performance hardware ensures real-time calculation for all relays at every sampling interval. With an internal high-speed bus and intelligent I/O, the device features flexible hardware configuration, versatility, and ease of expansion and maintenance.

- Modular hardware and software design

The device provides comprehensive protection functions. Each protection element is designed in a modular manner, independent of each other, and can be flexibly configured.

- Strong electromagnetic compatibility (EMC)

With an integrated front panel and fully enclosed chassis, strong and weak current circuits are strictly separated, eliminating the traditional backplane wiring method. Corresponding anti-interference measures are also adopted in software design, greatly improving the device's anti-interference capability, while its external electromagnetic radiation meets relevant standards.



RWCME-I Shunt Capacitor Online Early Warning and Protection Device

- Easy debugging and maintenance

It is equipped with a user-friendly human-machine interface (HMI) and convenient on-site device testing functions.

- Powerful communication functions

It features flexible communication methods, equipped with up to one 100Mbps Ethernet interface and two RS-485 serial ports. It supports the standard Modbus communication protocol and the new-generation substation communication standard DL/T860 (IEC 61850).

- Complete event recording function

It has complete SOE (Sequence of Events) records and storage for current protection tripping data, which can be exported to a USB flash drive for user analysis.

Supports both AC and DC power supply

- The device supports both AC and DC power supply.

1.4 Ordering Instructions

- Two options are available for the current transformer secondary rated current: 1A or 5A.
- Two options are available for the DC power supply voltage level: 220V or 110V.
- Two options are available for the binary input module voltage level: 220V or 110V.
- Wiring configuration of the shunt capacitors: single-star / double-star.
- Unbalance protection modes for shunt capacitors: open-delta voltage protection phase voltage differential protection / double-star neutral unbalanced current protection / bridge differential current protection.
- Whether a discharge coil installed across the capacitor terminals is required.

1.5 Product Standards

This product complies with the corporate standard of Zhejiang Hongyan Electric Co., Ltd.: QB/HY CM01 *General Technical Conditions for On-line Early Warning and Protection Devices for Shunt Capacitors*.

Chapter 2 Technical Parameters

2.1 Electrical Parameters

Item No.	Item	Sub-item	Technical Specification
1	Dimensions & Opening Dimensions	Overall Dimensions	270 × 175 × 180 (L × W × H, mm)
		Opening Dimensions	232 × 179 (L × W, mm)
2	Operating Power Supply	Operating Power Source	AC/DC 100~240V (*)
3	Rated Sampling	Rated Voltage	AC 100V / ±0.5%



RWCME-I Shunt Capacitor Online Early Warning and Protection Device

Item No.	Item	Sub-item	Technical Specification
		Rated Current	1A / 5A / ±0.5% (*)
4	Operating Environment	Operating Temperature	-20°C ~ +70°C (or -40°C ~ +85°C)
		Relative Humidity	≤95%
		Pollution Degree	III
5	Input Circuits	Analog Voltage Input	0~120V, 7/10 class (*)
		CT Input	0~1A/5A, 3/7 class (*)
		Temperature Input	3 channels
		Comprehensive Error	<0.5%
6	Output Circuits	Number of Output Channels	10 channels (closing, tripping, protection, fault, early warning, alarm, blocking, and 3 spare)
		Relay Contact Capacity	AC 250V, 5A; DC 220V, 5A
		Pulse Duration	≤2S
7	Digital Inputs	Digital Input Quantity	10 channels (status, isolation, grounding, cabinet door, run/stop, blocking, fire protection, and 3 spare)

Note: Items marked with * are required to be specified at the time of order.

2.2 Environmental Condition Parameters

Item	Parameter Value
Applicable Standard	GB/T 14047-1993 (idt IEC 60225-1:2009)
Operating Temperature Range	-20°C ~ +55°C
Storage and Transportation Temperature Range	-40°C ~ +70°C
Relative Humidity	5% ~ 95%, no condensation or icing inside the equipment

2.3 Communication Ports

2.3.1 RS-485 Interface

Item	Parameter Value
------	-----------------



Item	Parameter Value
Baud Rate	4.8kbit/s, 9.6kbit/s, 19.2kbit/s, 38.4kbit/s, 57.6kbit/s, 115.2kbit/s
Communication Protocol	Modbus RTU
Maximum Load	32
Transmission Distance	< 500 m
Wiring Type	Shielded twisted pair cable

2.3.2 Ethernet Interface

Item	Parameter Value
Interface Type	RJ-45
Transmission Speed	100Mbit/s, auto-adaptive
Transmission Standard	10Base-T/100Base-TX
Transmission Distance	< 100 m
Communication Protocol	IEC 60870-5-103:1997 or IEC 61850
Wiring Type	Category 5 shielded network cable

Chapter 3 Working Principle

3.1 Overview

To maintain the normal and stable operation of the power system, a large number of shunt reactive power compensation equipment are required. At home and abroad, power capacitor banks are commonly used as reactive power compensation equipment. To ensure the safe and stable operation of power capacitor banks, series reactors are required to suppress the closing inrush current of capacitors and prevent the amplification of high-order harmonics in the power grid. Series reactors have become an indispensable part of the complete set of power capacitor devices.

At the same time, the safe operation of power capacitors also requires discharge components. In addition to discharge resistors, discharge coils can also reduce the voltage at the

terminals of power capacitors below the required value within the specified time. Only the safe and stable operation of series reactors and discharge coils can ensure the normal commissioning of power capacitor banks. Therefore, there is an urgent need to realize on-line monitoring of the complete set of power capacitor devices and provide early warning for their faults.

To achieve the normal operation of high-voltage shunt power capacitors, supporting equipment such as series reactors, disconnectors, arresters, circuit breakers, and discharge coils are usually required. The on-site wiring diagram of the complete set of high-voltage shunt power capacitor devices is shown in the figure below.



Figure 3.1 On-site Wiring of High-voltage Shunt Power Capacitor Complete Set

The typical electrical principle wiring diagram of the high-voltage shunt power capacitor complete set is shown in the figure below.

RWCME-I Shunt Capacitor Online Early Warning and Protection Device

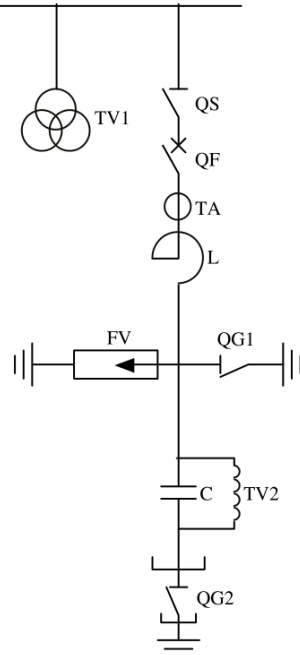

Figure 3.2 Electrical Principle Connection Diagram of the High-Voltage Shunt Power Capacitor Complete Set

In the diagram:

- C = Power capacitor bank
- TV1 = Busbar-side voltage transformer
- TA = Current transformer
- QF = Circuit breaker
- QS = Disconnector
- L = Series reactor
- QG1 and QG2 = Earthing switches
- FV = Metal-oxide surge arrester
- TV2 = Discharge coil

Current on-line monitoring technologies for power capacitors obtain voltage signals in two ways:

Obtain the operating voltage of the capacitor bank from the busbar-side voltage transformer TV1, and indirectly calculate the operating voltage of the capacitor via formulas.

Directly obtain the operating voltage of the capacitor from the secondary side of the capacitor discharge coil TV2.

Both methods have significant limitations in practical field applications:

For Method ①, calculating the capacitor operating voltage requires computation based on the reactor's reactance rate. Since the actual reactance rate of series reactors often has deviations, the accuracy of the calculated voltage cannot be guaranteed. This method also cannot be applied to graded compensation scenarios and does not consider the impact of reactor faults on monitoring.

For Method ②, it does not account for the impact of discharge coil faults on monitoring accuracy, and cannot be used for on-line monitoring of capacitors that use discharge resistors as discharge components in practical projects.

To address the shortcomings of the above two methods, and to facilitate the analysis and calculation of the real-time capacitance C of the power capacitor and the real-time inductance L of the reactor, the electrical principle connection shown in the figure above is equivalent to the circuit schematic shown in the following figure.

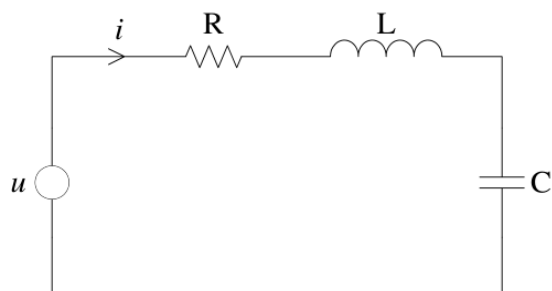

Figure 3.3 Equivalent Circuit Schematic Diagram of the High-Voltage Shunt Power Capacitor Complete Set

During monitoring, the current i in the above figure is obtained from the circuit current transformer TA in Figure 3.2, and the voltage u is obtained from the busbar-side voltage

transformer TV1 in Figure 3.2. Full-wave Fourier transform is performed on the collected data to extract its fundamental component and the 2nd to 25th harmonic components. These are used to detect and calculate parameters such as the active power loss of the power capacitor device, output reactive power, capacitive impedance, inductive impedance, capacitance value, inductance value, as well as the 2nd to 25th harmonic impedance and loop harmonic current.

3.2 Capacitor Fault Early Warning

Since the internal breakdown process of a capacitor is very short, the capacitance changes significantly before and after breakdown, which can obviously be used as a signal for protection. The key technology of this project is fault early warning before capacitor breakdown. Before breakdown and failure, by monitoring the variation characteristic quantities of various parameters and based on a large amount of historical operation data, the relationship between capacitor failure and its historical operation state can be explained, which greatly improves the operation reliability and maintenance efficiency of capacitors.

For capacitance-based fault diagnosis, on the basis of the above monitoring of fundamental voltage and fundamental current, since the active power loss of the capacitor is very small (dielectric loss factor $\tan\delta \approx 0.02\%$), the current through the capacitor is almost purely capacitive. The capacitance value can be obtained from the measured data. By comparing with historical data, the capacitance variation can be obtained, including longitudinal and horizontal comparison of capacitance values in the same bank. An alarm will be issued for capacitors whose variation exceeds a certain standard.

1) Capacitance Monitoring

Capacitance monitoring can directly reflect the operation status of power capacitors, and different faults of capacitors will affect the capacitance value. Through high-speed and accurate sampling of the current flowing through the power capacitor and the secondary voltage of the busbar-side voltage transformer of the complete power capacitor device, the fast Fourier transform algorithm is adopted to decompose the fundamental and harmonic components in voltage and current to obtain accurate real-time data, and calculate the capacitance value to realize on-line capacitance monitoring.

Therefore, if the internal element circuit of a capacitor is generally not equipped with



RWCME-I Shunt Capacitor Online Early Warning and Protection Device

internal fuses, the partial capacitor elements will be short-circuited when the internal insulation breaks down, its series-parallel structure will change accordingly, and the capacitance will increase. If the internal element circuit of a capacitor is equipped with internal fuses, the internal fuses for protection will blow when the current exceeds the threshold during internal insulation breakdown, resulting in a decrease in capacitance.

DL/T393-2010 Code for Condition-Based Maintenance Test of Power Transmission and Transformation Equipment stipulates that:

(1) Requirements for the standard deviation between the capacitance value C of the capacitor bank and its rated value are as follows:

- For capacitor banks with a capacity below 3Mvar: -5% ~ 10%
- For capacitor banks with a capacity from 3Mvar to 30Mvar: 0% ~ 10%
- For capacitor banks with a capacity above 30Mvar: 0% ~ 5%

(2) The ratio of the maximum capacitance to the minimum capacitance at any two terminals shall not exceed 1.05.

Therefore, the normal threshold values for the capacitance C of high-voltage shunt capacitors are set as follows:

$$\left\{ \begin{array}{l} \sigma_1 = \frac{C_i - C_N}{C_N} \times 100\% \\ \sigma_2 = \frac{C_{\max}}{C_{\min}} \end{array} \right.$$

In the formula, the deviation of σ_1 shall comply with the range specified in (1); and the deviation of σ_2 shall comply with the requirement in (2), i.e., $\sigma_2 \leq 1.05$.

The on-line monitoring system calculates the real-time operating capacitance C of the power capacitor, and obtains the early warning values σ_1 and σ_2 based on the capacitance value. If either σ_1 or σ_2 exceeds the deviation range or the specified value, the on-line monitoring system will issue a fault early warning for the power capacitor.

(2) Operating Voltage Monitoring



RWCME-I Shunt Capacitor Online Early Warning and Protection Device

When power capacitors operate under long-term overvoltage conditions, the loop current increases, leading to excessive temperature rise of the capacitors, accelerating the aging of dielectric insulation, and easily causing insulation breakdown faults in the capacitors. Relevant national standards stipulate that when the operating voltage of a power capacitor is $1.1U_N$ (U_N is the rated voltage of the capacitor), the maximum continuous operating time per 24 hours is 12 hours; when the operating voltage is $1.15U_N$, the maximum continuous operating time per 24 hours is 30 minutes. Therefore, it is necessary to conduct on-line monitoring of the operating voltage of the power capacitor itself.

(3) On-line Monitoring of Dielectric Loss Factor $\tan\delta$

Under AC voltage, a power capacitor can be equivalent to a parallel model. When the insulation performance of the insulating material is good, it is actually non-conductive, and the resistive current is approximately zero. Except for the relatively small surface DC leakage current, only pure capacitive current flows through the capacitor, and at this time, the phase of the pure capacitive current leads the phase of the voltage across the device by 90° .

When defects occur in the insulating material, the insulation performance degrades, the equivalent parallel resistance decreases, and the resistive current component increases. At this time, the phase of the pure capacitive current leads the phase of the voltage across the device by less than 90° , resulting in active power loss.

Therefore, the ratio of the total resistive current vector I_R to the total capacitive current vector I_C of the dielectric is defined as $\tan\delta$, which is used to indicate the magnitude of the active power consumed by the device. The larger the value, the more active power is consumed by the power capacitor, and the more severe the temperature rise. $\tan\delta$ can sensitively reflect the insulation defects of the capacitor and monitor the operating status of the capacitor in real time.

4) Temperature-based Fault Diagnosis

If the ambient temperature is too high, it is used as a reference value for alarm. However,

the main basis for fault early warning diagnosis is the temperature of the capacitor shell. The shell temperature of a capacitor is affected by the ambient temperature, the operating capacity of the capacitor, the dielectric loss factor of the capacitor, and ventilation conditions. By measuring the reactive power of the capacitor during operation and calculating the active power loss and heat generation of the capacitor based on the difference between the shell temperature and the ambient temperature, the maximum internal temperature of the capacitor can be estimated. Based on the shell temperature and the maximum internal temperature of the capacitor, the degree of insulation aging of the internal dielectric is judged, and an early warning signal is issued for capacitors exceeding the alarm threshold

5) On-line Monitoring of Harmonics

The impact of harmonics on power capacitors cannot be ignored, and capacitor failures caused by various harmonics are common. The hazards of harmonics to capacitors mainly lie in two aspects:

(1) Since the capacitive reactance of a power capacitor decreases with increasing frequency, it presents extremely low impedance to various high-order harmonics, causing high-order harmonic currents to increase. Harmonic currents increase the active power loss of the capacitor, raising its temperature and leading to thermal aging of the equipment. Generally, for every 7~8°C increase in the temperature of a power capacitor, its service life is halved, seriously affecting the equipment's lifespan.

(2) Under the effect of a certain harmonic, the harmonic current may cause the capacitive reactance of the power capacitor to equal the equivalent inductive reactance of the harmonic current path, leading to system resonance. Harmonic voltages increase the RMS value of the voltage. Studies show that for every 10% increase in a capacitor's operating voltage, its service life is shortened by about half. At the same time, as the voltage across the capacitor increases, the active power loss of the capacitor increases rapidly with the square of the voltage, causing the heat generated by the capacitor to exceed the heat dissipated, raising the temperature of its internal dielectric, leading to thermal aging of the insulation and shortening the equipment's service life. Therefore, the presence of harmonic voltage accelerates both electrical and thermal aging of the equipment. In addition, the superposition of harmonic voltages also increases the peak voltage of the capacitor. When the initial phase angles of all harmonics are equal, the voltage reaches its highest peak, causing high-intensity partial discharges in the internal insulation and damaging the internal dielectric.

3.3 Reactor Fault Early Warning

The series reactor is an important component of the shunt capacitor device, with the main functions of limiting switching inrush current and suppressing high-order harmonics. According to practical field applications and research analysis, inter-turn short circuits in the reactor winding and core magnetic saturation are the main factors causing failures in dry-type reactors.

After a reactor fault occurs, the circulating current in the shorted coil greatly increases the power



RWCME-I Shunt Capacitor Online Early Warning and Protection Device

loss of the reactor, which can reach more than 16 times that during normal operation, and increases with the degree of coupling.

After a reactor fault occurs, the equivalent reactance of the reactor decreases only slightly, and its variation is far smaller than the change in reactor loss.

Therefore, judging whether the reactor has an inter-turn short circuit fault based on the rate of change of the reactor power loss has high sensitivity. In the complete power capacitor device, the active power losses of the series reactor and shunt capacitor account for the vast majority of the total loss of the entire set. The active power consumed by the complete power capacitor device, which is obtained through detection and calculation, minus the capacitor loss, is used as the basis for judging reactor faults. The maximum threshold for the active power change rate of the series reactor under normal conditions is set to 2. If the change rate is greater than 2, it is determined that there is an inter-turn short circuit fault in the series reactor winding, and an early warning can be issued for the series reactor fault.

$$\gamma = P_k / P_{k0} \leq 2$$

- γ : Loss change rate
- P_k : Measured and calculated active power loss of the reactor (unit: kW)
- P_{k0} : Initial test value of the reactor's active power loss (unit: kW)

When core magnetic saturation occurs in a core-type reactor, the reactance value drops sharply. The fault can be identified and warned by detecting the downward deviation of the reactance value.

3.4 Discharge Coil Fault Early Warning

In field applications, the voltage signal collected from the secondary side of the discharge coil can be taken as a comparison reference to realize early warning of discharge coil faults.

3.5 Fire Early Warning

Fire and explosion accidents occasionally occur during the operation of shunt capacitor devices, making fire detection and early warning of great significance for operational safety. Smoke detectors and automatic fire extinguishing devices are installed at appropriate positions inside the cabinet or frame of the shunt capacitor device. By detecting smoke inside the device combined with three-phase temperature monitoring, signals are sent to the local device for alarm. The device activates the fire extinguisher for fire suppression according to the set threshold. The equipped fire extinguisher can be controlled by the early warning device or automatically activated for fire extinguishing through self-detection.

3.6 Protection Functions of Capacitor Device

For in-service shunt capacitor devices, the system is equipped with three-phase overvoltage protection, three-phase undervoltage protection, three-stage current protection, open-delta voltage protection, neutral unbalanced current protection, bridge differential current protection, phase voltage differential protection and other functions, which are applicable to shunt capacitor devices with various configuration and wiring modes.

3.7 Fault Location Function of Capacitor Device

By monitoring the three-phase voltage, three-phase current, unbalanced current or voltage and their phase angles of the capacitor device, as well as the dielectric loss and surface temperature of capacitors, the faulty capacitor can be located in real time, and alarm signals can be promptly sent to operation and maintenance personnel. Meanwhile, fault diagnosis and analysis of capacitor defects help maintenance staff quickly locate faults and analyze fault causes, so as to conduct targeted maintenance on defects. It is of far-reaching significance to ensure the safe and stable operation of power capacitors and power grid.

Chapter 4 System Composition

The on-line monitoring, early warning and protection system for shunt capacitors consists of the on-line monitoring, early warning and protection device (main control system), capacitor shell wireless temperature measuring device, system monitoring voltage transformer, special discharge coil for capacitor monitoring, current transformer of shunt capacitor device, smoke detector, automatic fire extinguishing device and other components. The hardware structure of the main control system is described as follows.

4.1 Device Panel Layout

The figure below shows the front panel layout and rear panel layout of the device.

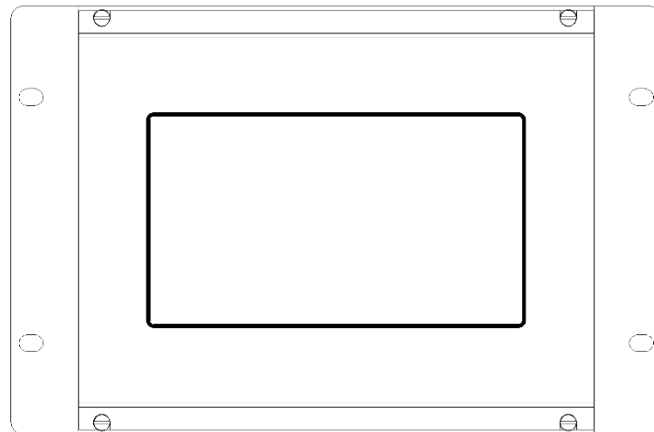

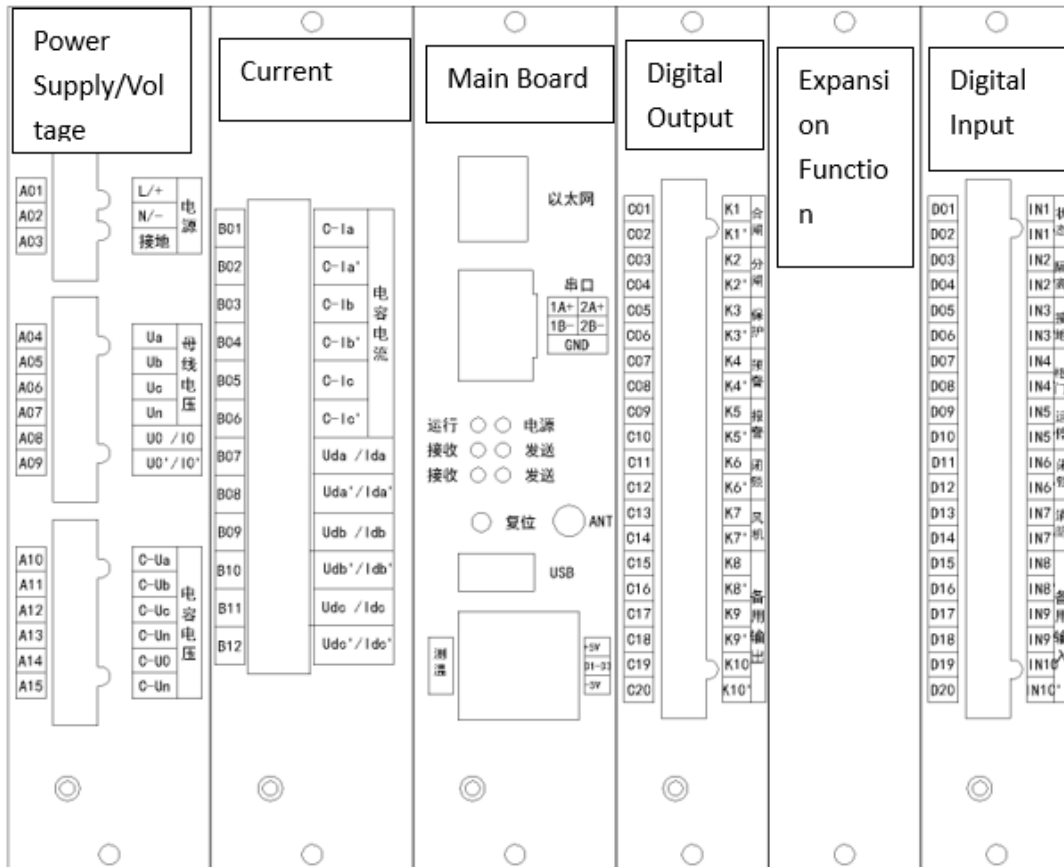

4.2 Structure and Installation

4.2.1 Mechanical Dimensions

The device adopts a fully enclosed 4U half-layer standard chassis, which can be installed in a cabinet assembly or locally mounted in a switchgear cabinet. The reference installation dimensions for switchgear mounting are shown in Figure 4.2-1.

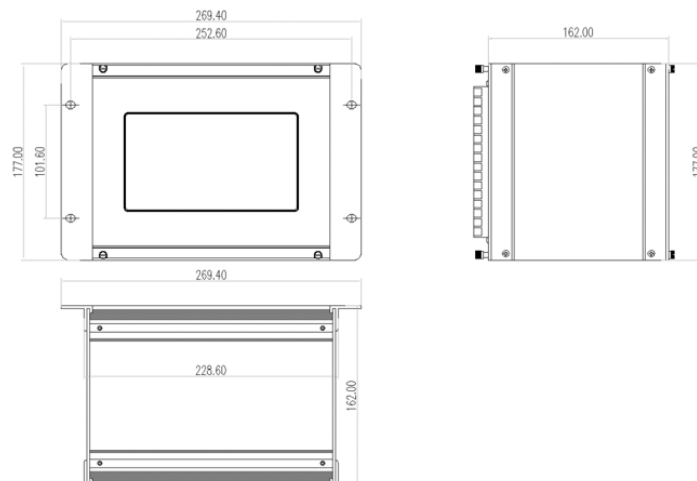

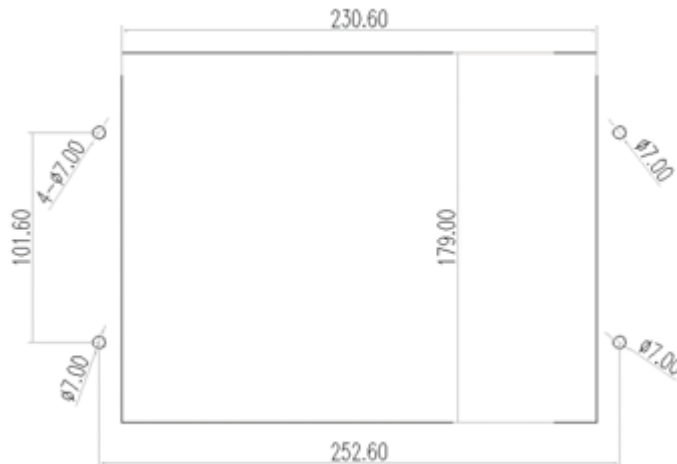

Figure 4.2-1



Note: During installation, sufficient space must be reserved above and below the opening in the cabinet or switchgear for heat dissipation of the device. All hardware modules of the device shall be correctly and tightly inserted into the corresponding slots of the device

4.3 Device Terminal Definition

The rear panel terminal diagram given in this section corresponds to the standard configuration of RWCME-I, and the expansion function board is optional.

4.4 Device Terminal Wiring Instruction

1. Voltage Section

Terminal No.	Symbol	Description
A13	C-Un	Capacitor voltage Un
A14	C-U0	Capacitor open delta voltage
A15	C-Un	Capacitor voltage Un

2. Current Section

Terminal No.	Symbol	Description
B01	C-Ia	Capacitor current Ia
B02	C-Ia'	Capacitor current Ia'
B03	C-Ib	Capacitor current Ib
B04	C-Ib'	Capacitor current Ib'
B05	C-Ic	Capacitor current Ic
B06	C-Ic'	Capacitor current Ic'
B07	Uda /Ida	Double-star neutral unbalance protection / Phase A voltage differential protection / Phase A bridge differential current protection *



RWCME-I Shunt Capacitor Online Early Warning and Protection Device

Terminal No.	Sym bol	Description
B08	Uda '/Ida'	(Corresponding pair for B07)
B09	Udb '/Idb'	Phase B voltage differential protection / Phase B bridge differential current protection *
B10	Udb '/Idb'	(Corresponding pair for B09)
B11	Udc '/Idc'	Phase C voltage differential protection / Phase C bridge differential current protection *
B12	Udc '/Idc'	(Corresponding pair for B11)

3. Main Board Section

Terminal No. / Group	Sy mbol	Description
Ethernet	RJ-45	IEC 61850 network communication interface
Serial Port	1A +, 1B-	RS485 communication 1
Serial Port	2A +, 2B-	RS485 communication 2
Serial Port	GN D	RS485 power negative, used to balance master-slave communication level
Temperature Sensing	+5 V	Positive power supply for 3 temperature sensors
Temperature Sensing	D1 -D3	Data lines for 3 temperature sensors
Temperature Sensing	-5V	Negative power supply for 3 temperature sensors

4. Digital Output Section

Terminal No.	Sy mbol	Description
C01	K1	Close: Normally open by default, pulse output
C02	K1'	(Corresponding pair for K1)
C03	K2	Open: Normally open by default, pulse output
C04	K2'	(Corresponding pair for K2)
C05	K3	Trip: Normally open by default, pulse output
C06	K3'	(Corresponding pair for K3)
C07	K4	Early warning: Normally open by default, normally closed output



RWCME-I Shunt Capacitor Online Early Warning and Protection Device

Terminal No.	Symbol	Description
C08	K4'	(Corresponding pair for K4)
C09	K5	Alarm: Normally open by default, normally closed output
C10	K5'	(Corresponding pair for K5)
C11	K6	Interlock: Normally open by default, normally closed output
C12	K6'	(Corresponding pair for K6)
C13	K7	Fan: Normally open by default, normally closed output
C14	K7'	(Corresponding pair for K7)
C15	K8	Spare output
C16	K8'	(Corresponding pair for K8)
C17	K9	Spare output
C18	K9'	(Corresponding pair for K9)
C19	K10	Spare output
C20	K10'	(Corresponding pair for K10)

5. Digital Input Section

Terminal No.	Symbol	Description
D01	IN1	Switch status input
D02	IN1'	(Corresponding pair for IN1)
D03	IN2	Isolator status input
D04	IN2'	(Corresponding pair for IN2)
D05	IN3	Earthing switch status input
D06	IN3'	(Corresponding pair for IN3)
D07	IN4	Cabinet door status input
D08	IN4'	(Corresponding pair for IN4)
D09	IN5	Early warning reset status input
D10	IN5'	(Corresponding pair for IN5)
D11	IN6	External interlock status input
D12	IN6'	(Corresponding pair for IN6)
D13	IN7	Fire protection activation status input
D14	IN7'	(Corresponding pair for IN7)
D15	IN8	Interlock reset status input
D16	IN8'	(Corresponding pair for IN8)
D17	IN9	Spare input
D18	IN9'	(Corresponding pair for IN9)
D19	IN10	Spare input

Terminal No.	Symbol	Description
D20	IN10'	(Corresponding pair for IN10)

Note: Items marked with "*" are optional configuration items that require both hardware and software support. When placing an order, the capacitor wiring configuration and unbalance protection method must be specified (open-delta voltage protection / double-star neutral unbalanced current protection / phase voltage differential protection / bridge differential current protection; only one protection method is allowed to be configured at the same time).

4.5 Device Interface Wiring Diagram

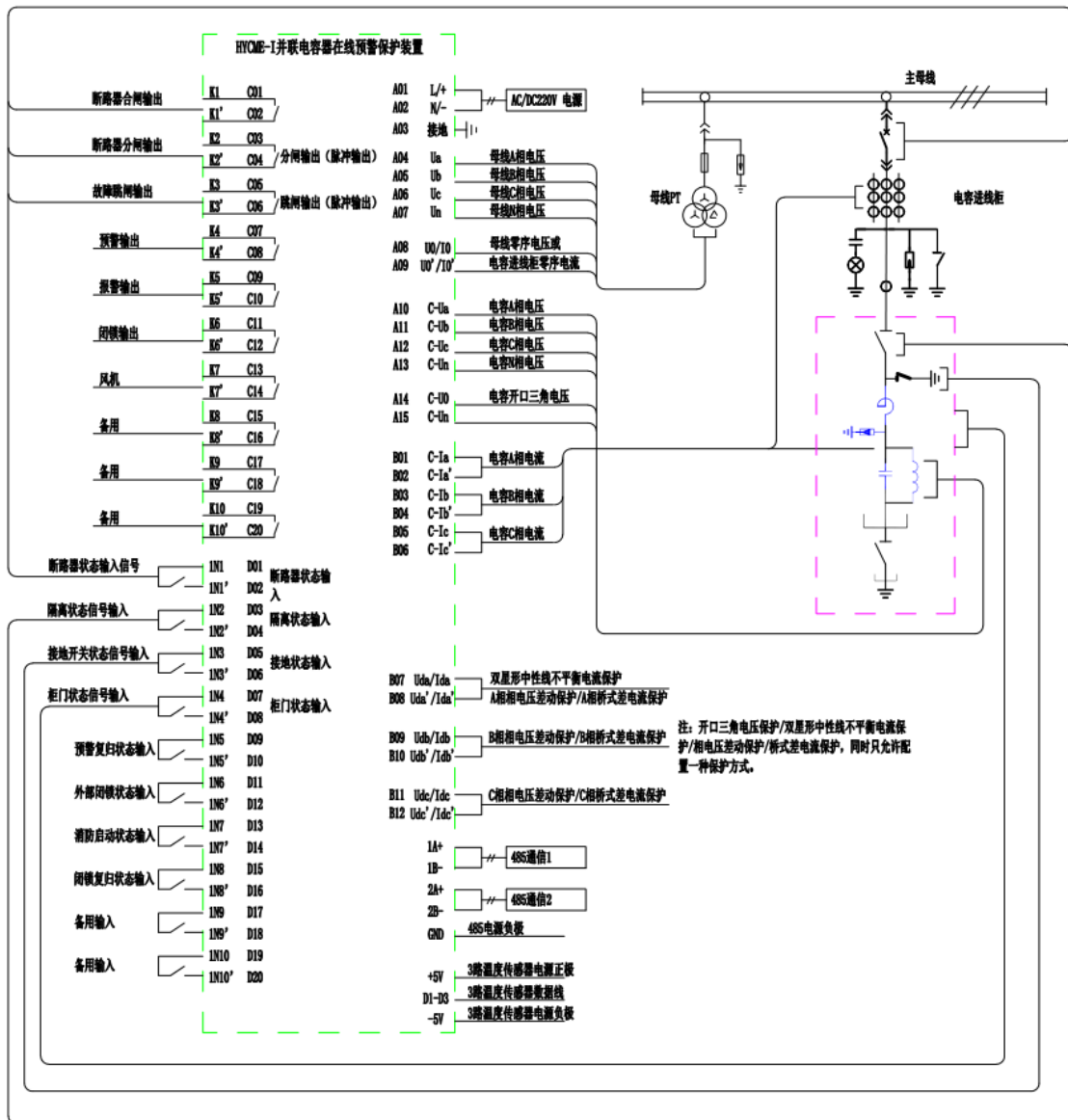

Symbol	Description
U0	Unbalanced voltage of shunt capacitor bank, V (valid for open-delta voltage protection)
I0	Unbalanced current of shunt capacitor bank, A (valid for neutral unbalanced current protection)



Symbol	Description
L-Ua/L-Ub/L-Uc	Operating terminal voltage of the series reactor in the shunt capacitor bank, kV
LCZ-a/LCZ-b/LCZ-c	Fundamental impedance of the capacitor-reactor loop in the shunt capacitor bank, Ω
XL-a/XL-b/XL-c	Reactance rate of the shunt capacitor bank, %
COS Φ -a/COS Φ -b/COS Φ -c	Power factor of the shunt capacitor bank loop
L-Pa/L-Pb/L-Pc	Active power loss of the series reactor in the shunt capacitor bank, W
C σ -a/C σ -b/C σ -c	Capacitance deviation of the phase capacitors in the shunt capacitor bank, %
L σ -a/L σ -b/L σ -c	Inductance deviation of the phase reactors in the shunt capacitor bank, %
ω σ -a/ω σ -b/ω σ -c	Input voltage frequency deviation of the shunt capacitor bank, %
T1/T2/T3	3-channel temperatures of the shunt capacitor bank, °C
tngδa/tngδb/tngδc	Dielectric loss of phase capacitors in the shunt capacitor bank
C-Qa/C-Qb/C-Qc	3-phase reactive power of the shunt capacitor bank, kVAr

Note: The above parameters are the displayed data items of the standard early warning device,



subject to the actually selected and adopted device. Items marked with * are alternative functions with only one selectable.

5.2 Harmonic Measurement Interface

The harmonic measurement interface mainly displays the 1st to 27th order bus harmonic voltage distortion rate, the 1st to 27th order capacitor terminal harmonic voltage distortion rate, and the 1st to 27th order harmonic current of the capacitor loop. It consists of three pages in total, for analyzing the operating state and early warning faults of capacitors during operation.

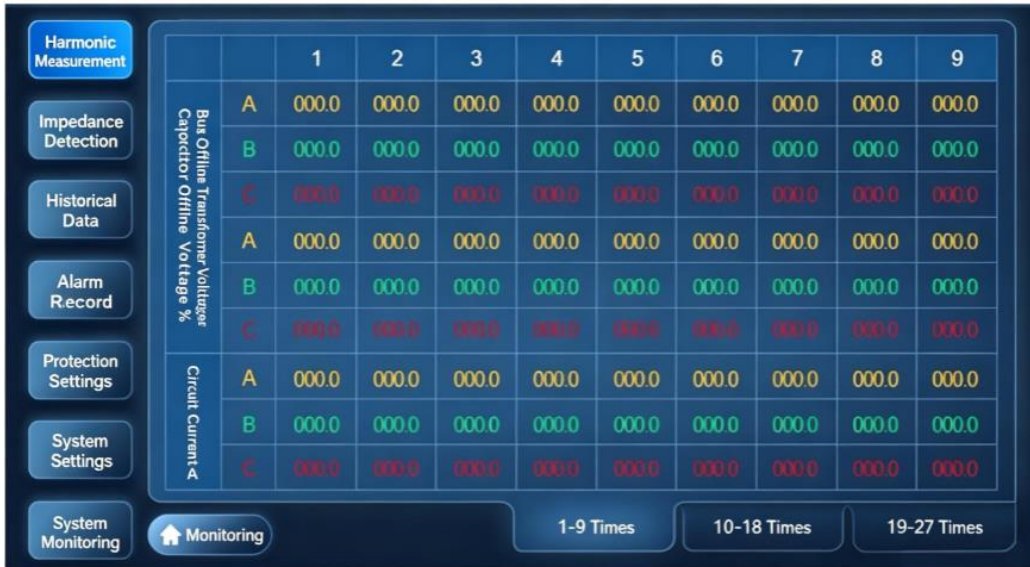

5.3 Impedance Measurement Interface

The impedance measurement interface mainly displays the measured 1st to 27th order impedance of the capacitor-reactor loop, 1st to 27th order impedance of the capacitor, and 1st to 27th order impedance of the reactor. It consists of three pages for analyzing the operating status and early warning faults of the capacitor bank during operation.

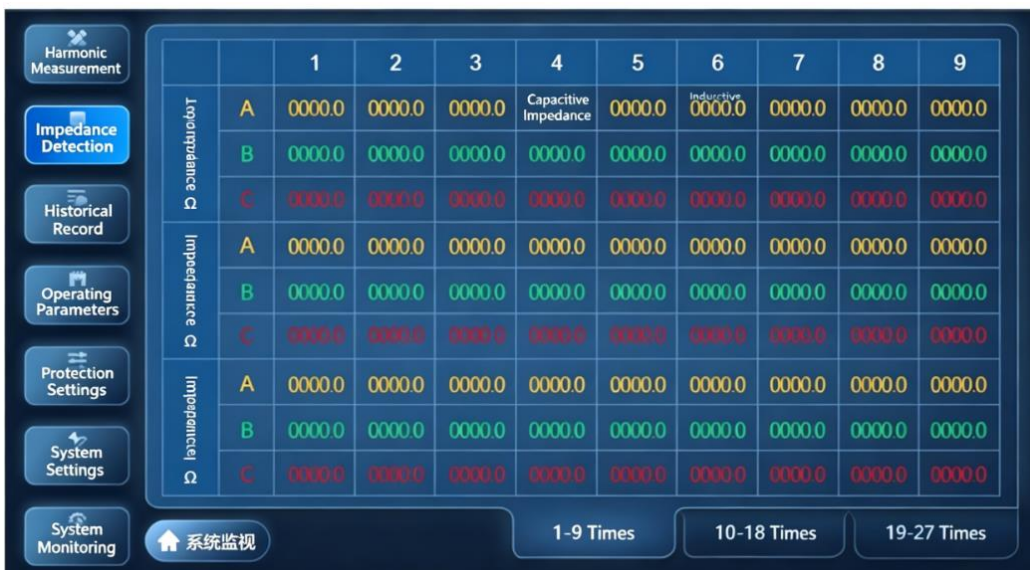

5.4 Historical Data Interface

The historical data interface mainly displays hourly-recorded data including three-phase system voltage, three-phase capacitor terminal voltage and current, three-phase capacitor impedance, three-phase reactor impedance, etc., for analyzing the operating status and early warning faults of the capacitor bank during operation. There are three pages in total, and historical data can be queried on each page via the Previous Page and Next Page buttons.

Time	Date	Ua	Ub	Uc	C-Ua	C-Ub	C-Uc
13:14:34	2023/01/12	0.00	0.00	0.00	0.00	0.00	0.00
13:14:34	2023/01/12	0.00	0.00	0.00	0.00	0.00	0.00
13:14:34	2023/01/12	0.00	0.00	0.00	0.00	0.00	0.00
13:14:34	2023/01/12	0.00	0.00	0.00	0.00	0.00	0.00
13:14:34	2023/01/12	0.00	0.00	0.00	0.00	0.00	0.00
13:14:34	2023/01/12	0.00	0.00	0.00	0.00	0.00	0.00
13:14:34	2023/01/12	0.00	0.00	0.00	0.00	0.00	0.00
13:14:34	2023/01/12	0.00	0.00	0.00	0.00	0.00	0.00
13:14:34	2023/01/12	0.00	0.00	0.00	0.00	0.00	0.00
13:14:34	2023/01/12	0.00	0.00	0.00	0.00	0.00	0.00

5.5 Alarm Record Interface

The alarm record interface mainly displays the events and information of early warning and protection actions, as well as the latest protection action values. It is used for analyzing the operating status and early warning faults of the shunt capacitor bank during operation, and is displayed on multiple pages according to the number of recorded data.

Time	Date	Message
13:14:34	2023-01-12	Opening Failure
13:14:34	2023-01-12	Under-Voltage Protection-C
13:14:34	2023-01-12	Under-Voltage Protection-B
13:14:34	2023-01-12	Under-Voltage Protection-A
01:14:34	2023-01-12	Over-Voltage Protection-B
01:14:34	2023-01-12	Over-Voltage Protection-C
01:14:34	2023-01-12	Over-Voltage Protection-A
13:14:00	2023-01-13	Over-Current Protection-C
13:14:00	2023-01-13	Protection-B
13:14:00	2023-01-13	Over-Current Protection-A

5.6 Operating Parameter Interface

The operating parameter interface is mainly used to set the fixed value parameters of the shunt capacitors for the operation and control of the device. These fixed value parameters need to be



RWCME-I Shunt Capacitor Online Early Warning and Protection Device

recorded and saved for a long time. The default password to enter the operating parameter window is: 2222.

The operating parameters are the control and setting parameters of the device, which can be set by clicking to bring up the numeric keypad. After setting, click the "Set" button to save. The specific fixed value parameters are described in the following table:

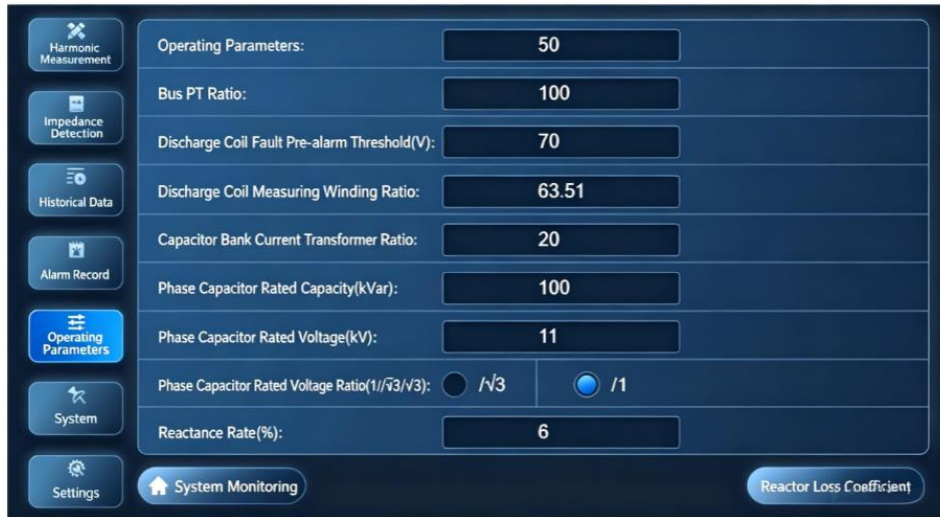

Parameter	Value Range	Unit	Remarks
System Frequency	1-99	Hz	Rated frequency of the connected system. Default = 50
Busbar PT Ratio	1-9999		Ratio of the sampling voltage transformer. Example: If the PT ratio is 10000:100, set to 100. Default = 100
Discharge Coil Fault Warning Reference Value	1-9999		Set as 1.3 times the real-time measured secondary value of the capacitor voltage
Discharge Coil Measurement Winding Ratio	1-999.99		Voltage ratio of the primary/secondary winding of the discharge coil in the capacitor bank. Example: Primary voltage = 11/√3 kV, secondary voltage = 0.1 kV, ratio = 63.51. Default = 63.51
Capacitor Bank CT Ratio	1-9999		Ratio of the current transformer in the capacitor bank. Example: If the CT ratio is 1000A:5A, set to 200. Default = 40
Phase Capacitor Rated Capacity	1-9999	kvar	Rated capacity of the single-phase capacitor in the capacitor bank. Example: For a 600 kvar capacitor bank, the phase capacitor capacity is 200 kvar, so set to 200. Default = 200
Phase Capacitor Rated Voltage	0.0-99.99	V	Rated voltage of the phase capacitor in the capacitor bank. Example: If the capacitor bank voltage is 11 kV, the

Parameter	Value Range	Unit	Remarks
			phase capacitor rated voltage is $11/\sqrt{3}$ kV, so set to $11/\sqrt{3}$. Default = $11/\sqrt{3}$
Reactance Rate	0.0 1-99.99		Rated reactance rate installed in the capacitor bank; set to 0 if no reactor is present. Default = 5

Note: The above parameters are the operating setting items of the standard early warning device, subject to the actually selected and adopted device



Note: The reactor loss coefficient is subject to the reactor selected for the actual project. The capacity of dry-type iron-core reactors is set as the three-phase total capacity, while the capacity of dry-type air-core reactors is set as the single-phase capacity. The reactor loss complies with the requirements of JB/T 5346 Series Reactors for High-Voltage Shunt Capacitors.

5.7 Protection Setting Interface

The protection setting interface is mainly used to set the setting parameters for early warning protection and conventional protection of shunt capacitors. Each protection function has optional action options: Disable, Early Warning, Alarm, Opening, Tripping, and Interlock. These setting parameters need to be recorded and saved for a long time. The password to enter the protection setting window is: 2222, and the interface consists of seven pages in total.



RWCME-I Shunt Capacitor Online Early Warning and Protection Device



Parameter	Value Range	Unit	Remarks
Overvoltage Protection Setting	0-999.99		Secondary protection value for system overvoltage. When the system voltage exceeds this value, opening and alarm actions are triggered, with automatic reset after voltage recovery. Default = 120
Overvoltage Protection Time Delay	0-99.99		Operating time delay for overvoltage protection. Default = 1
Undervoltage Protection Setting	0-999.99		Secondary protection value for system undervoltage. When the system voltage drops below this value, opening and alarm actions are triggered, with automatic reset after voltage recovery. Default = 80
Undervoltage Protection Time Delay	0-99.99		Operating time delay for undervoltage protection. Default = 1
Zero-sequence Overvoltage Setting (Unbalanced Voltage Protection Value)	0-99.99		Overvoltage protection setting for capacitor open-delta voltage. When the capacitor open-delta voltage exceeds this value, trip, alarm and interlock actions are triggered; manual unlocking is required after fault clearance. Default = 5
Zero-sequence Overvoltage Protection Time Delay	0-9.99		Time delay for unbalanced voltage protection. Default = 0.2
Total Harmonic Voltage Distortion Rate Limit	0-999.99		Total harmonic voltage distortion rate of the system voltage. When the harmonic distortion rate exceeds this value, opening and alarm actions are triggered, with automatic reset after recovery. Default = 15
Total Harmonic Voltage Distortion Rate	0-99.99		Time delay for harmonic voltage protection. Default = 0.5



RWCME-I Shunt Capacitor Online Early Warning and Protection Device

Parameter	Value Range	Unit	Remarks
Limit Time Delay			



Parameter	Value Range	Unit	Remarks
Overcurrent Instantaneous Protection	0-999.99		Capacitor instantaneous overcurrent protection. When the capacitor operating current exceeds this value, trip, alarm and interlock actions are triggered; manual unlocking is required after fault clearance. Recommended setting: 5~10 times the rated capacitor current. Default = 10
Time-lag Overcurrent Instantaneous Protection	0-999.99		Capacitor time-lag instantaneous overcurrent protection. When the capacitor operating current exceeds this value, trip, alarm and interlock actions are triggered; manual unlocking is required after fault clearance. Recommended setting: 3~5 times the rated capacitor current. Default = 6
Time-lag Overcurrent Instantaneous Protection Time Delay	0-99.99	Time	Operating time delay for time-lag instantaneous overcurrent protection. Default = 0.05
Overcurrent Protection Setting	0-999.99		Capacitor overcurrent protection value. When the capacitor operating current exceeds this value, trip, alarm and interlock actions are triggered; manual unlocking is required after fault clearance. Recommended setting: 1.35~1.55 times the rated capacitor current. Default = 2.5
Overcurrent	0-		Operating time delay for overcurrent protection. Default



RWCME-I Shunt Capacitor Online Early Warning and Protection Device

Parameter	Value Range	Unit	Remarks
Protection Time Delay	0-99.99	s	Default = 0.8
Unbalanced Current Protection Setting *	0-999.99	A	Neutral line unbalanced current protection value for capacitors. When the capacitor operating current exceeds this value, trip, alarm and interlock actions are triggered; manual unlocking is required after fault clearance. Default = 0.5
Unbalanced Current Protection Time Delay	0-99.99	s	Operating time delay for unbalanced current protection. Default = 0.2

Note: Items marked with "*" are optional configuration items that require both hardware and software support. When placing an order, the capacitor wiring configuration and unbalance protection method must be specified (open-delta voltage protection / double-star neutral unbalanced current protection / phase voltage differential protection / bridge differential current protection; only one protection method is allowed to be configured at the same time).



Parameter	Value Range	Unit	Remarks
Reactor 3rd/5th Harmonic Current Overlimit Warning	0-99.99	%	Overlimit warning protection for the reactor operating under 3rd or 5th harmonic current. When the 3rd and 5th harmonic current content of the reactor exceeds this value, opening and warning actions are triggered, with automatic reset after harmonic current recovery. Default = 35
Reactor 3rd/5th Harmonic Current Overlimit	0-99.99	s	Time delay for this protection. Default = 0.5



RWCME-I Shunt Capacitor Online Early Warning and Protection Device

Parameter	Value Range	Unit	Remarks
Time Delay			
Total Harmonic Current Distortion Rate Overlimit	0-99.99		Overlimit warning protection for the reactor operating under total harmonic current. When the total harmonic current content of the reactor exceeds this value, opening and warning actions are triggered, with automatic reset after harmonic current recovery. Default = 20
Total Harmonic Current Overlimit Time Delay	0-99.99		Time delay for this protection. Default = 0.5
Capacitance Lower Deviation Limit	0-99.99		Lower limit of the negative deviation of the phase capacitance in the capacitor bank. When the phase capacitance is less than this value, warning and alarm actions are triggered, with automatic reset after recovery. Default = -5%
Capacitance Upper Deviation Limit	0-99.99		Upper limit of the positive deviation of the phase capacitance in the capacitor bank. When the phase capacitance exceeds this value, warning and alarm actions are triggered, with automatic reset after recovery. Default = +10%
Capacitance Adjustment Coefficient	0-9.99		Adjustment coefficient for capacitance detection accuracy. Default = 1
Capacitance Deviation Alarm Time Delay	0-99.99		Time delay for this protection. Default = 5



Parameter	Value Range	Unit	Remarks



RWCME-I Shunt Capacitor Online Early Warning and Protection Device

Parameter	Value Range	Unit	Remarks
Capacitor Dielectric Loss Factor $\tan \delta$ Limit	0-9.9999		Limit value of the capacitor dielectric loss factor. When the dielectric loss exceeds this value, warning and alarm actions are triggered, with automatic reset after recovery. Default = 0.005
Capacitor Dielectric Loss Factor Exceedance Time Delay	0-99.99		Time delay for this protection. Default = 5
Discharge Coil Fault Warning	0-99.99		When the deviation of the detected secondary output value of the discharge coil exceeds this value, warning and alarm actions are triggered, with automatic reset after recovery. Default = 20
Discharge Coil Warning Deviation Exceedance Time Delay	0-99.99		Time delay for this protection. Default = 5
Inductance Lower Deviation Limit	0-99.99		Lower limit of the negative deviation of the phase inductance in the capacitor bank. When the phase inductance is less than this value, warning and alarm actions are triggered, with automatic reset after recovery. Default = -5%
Inductance Upper Deviation Limit	0-99.99		Upper limit of the positive deviation of the phase inductance in the capacitor bank. When the phase inductance exceeds this value, warning and alarm actions are triggered, with automatic reset after recovery. Default = +10%
Inductance Adjustment Coefficient	0-9.99		Adjustment coefficient for inductance detection accuracy. Default = 1
Inductance Deviation Alarm Time Delay	0-99.99		Time delay for this protection. Default = 5



RWCME-I Shunt Capacitor Online Early Warning and Protection Device



Parameter	Value Range	Unit	Remarks
Reactor Loss Deviation Overlimit Value	0-999.99		Allowable deviation value of the reactor active power loss. Excessive deviation indicates a high probability of inter-turn short-circuit fault inside the reactor. When the reactor active power loss exceeds this setting, trip, warning, alarm and interlock actions are triggered; manual unlocking is required after fault clearance. Default = 80
Reactor Inter-turn Short-circuit Delay	0-99.99	Time	Time delay for this protection. Default = 1
Reactor Magnetic Saturation Fault Protection Limit	0-99.99		Lower deviation limit of the phase inductance value in the capacitor bank for magnetic saturation protection. When the phase inductance value is less than this value, trip, warning, alarm and interlock actions are triggered; manual unlocking is required after fault clearance. Default = -20%
Reactor Magnetic Saturation Protection Delay	0-99.99	Time	Time delay for this protection. Default = 1
Capacitor Bank Resonance Frequency Lower Deviation Limit	0-99.99		Lower deviation value of the resonance frequency of the capacitor bank loop. Excessive deviation indicates changes in the impedance of the capacitor or reactor, posing a risk of resonance with the system. When the lower deviation of the resonance frequency is less than this setting, trip, warning, alarm and interlock actions are triggered; manual unlocking is required after fault clearance. Default = -15
Capacitor Bank Resonance Frequency Upper Deviation Limit	0-99.99		Upper deviation value of the resonance frequency of the capacitor bank loop. Excessive deviation indicates changes in the impedance of the capacitor or reactor, posing a risk of resonance with the system. When the upper deviation of the resonance frequency is greater than this setting, trip, warning, alarm and interlock actions are triggered; manual unlocking is required after fault clearance. Default = 15



RWCME-I Shunt Capacitor Online Early Warning and Protection Device

Parameter	Value Range	Unit	Remarks
Resonance Frequency Upper Deviation Limit	+99.99		capacitor bank loop. Excessive deviation indicates changes in the impedance of the capacitor or reactor, posing a risk of resonance with the system. When the upper deviation of the resonance frequency exceeds this setting, trip, warning, alarm and interlock actions are triggered; manual unlocking is required after fault clearance. Default = +10
Capacitor Bank Resonance Frequency Deviation Protection Time Delay	0-99.99		Time delay for this protection. Default = 1



Parameter	Value Range	Unit	Remarks
Differential Current Protection *	0-999.99		Capacitor bridge differential current protection setting. When the capacitor differential current exceeds this value, trip, alarm and interlock actions are triggered; manual unlocking is required after fault clearance. Default = 1, disabled by default.
Differential Current Protection Time Delay	0-99.99		Time delay for differential current protection. Default = 0.2
Differential Voltage Protection *	0-999.99		Capacitor phase voltage differential protection setting. When the capacitor phase voltage differential value exceeds this value, trip, alarm and interlock actions are triggered; manual unlocking is required after fault clearance. Default =

Parameter	Value Range	Unit	Remarks
			5, disabled by default.
Differential Voltage Protection Time Delay	0-99.99		Time delay for differential voltage protection. Default = 0.2
1st Circuit High Temperature Fan Start Setting	0-999	°C	Capacitor bank temperature setting. When the detected temperature exceeds this value, the fan start action is triggered after a delay, with automatic reset after recovery. Default = 40
1st Circuit High Temperature Fan Start Time Delay	0-999		Time delay for this function. Default = 10
1st Circuit Ultra-high Temperature Protection Setting	0-999	°C	Capacitor bank temperature setting. When the detected temperature exceeds this value, opening and alarm actions are triggered, with automatic reset after recovery. Default = 60
1st Circuit Ultra-high Temperature Protection Time Delay	0-999		Time delay for this protection. Default = 10

Note: Items marked with "*" are optional configuration items that require both hardware and software support. When placing an order, the capacitor wiring configuration and unbalance protection method must be specified (open-delta voltage protection / double-star neutral unbalanced current protection / phase voltage differential protection / bridge differential current protection; only one protection method is allowed to be configured at the same time).



Parameter	Value Range	Unit	Remarks
2nd Circuit High Temperature Fan Start Setting	0-999	°C	Capacitor bank temperature setting. When the detected temperature exceeds this value, the fan start action is triggered after a delay, with automatic reset after recovery. Default = 40
2nd Circuit High Temperature Fan Start Time Delay	0-999		Time delay for this function. Default = 10
2nd Circuit Ultra-high Temperature Protection Setting	0-999	°C	Capacitor bank temperature setting. When the detected temperature exceeds this value, opening and alarm actions are triggered, with automatic reset after recovery. Default = 60
2nd Circuit Ultra-high Temperature Protection Time Delay	0-999		Time delay for this protection. Default = 10
3rd Circuit High Temperature Fan Start Setting	0-999	°C	Capacitor bank temperature setting. When the detected temperature exceeds this value, the fan start action is triggered after a delay, with automatic reset after recovery. Default = 40
3rd Circuit High Temperature Fan Start Time Delay	0-999		Time delay for this function. Default = 10
3rd Circuit Ultra-high Temperature Protection Setting	0-999	°C	Capacitor bank temperature setting. When the detected temperature exceeds this value, opening and alarm actions are triggered, with automatic reset after recovery. Default = 60
3rd Circuit Ultra-high Temperature Protection Time Delay	0-999		Time delay for this protection. Default = 10

Note: The above parameters are the operating setting items of the standard early warning device, subject to the actually selected and adopted device.

5.7 System Settings Interface

The system settings interface is mainly used to configure parameters such as the device communication address, baud rate, touch sound on/off, screen saver time, Chinese/English language selection, system time, etc. It also provides functions for password modification and manual system reset. The password to enter the system settings window is: 2222.



Communication with the RTU can be realized via the RS-485 serial port or Ethernet using the ModBus communication protocol. With this function, information such as the device's operating status, real-time measurement data, real-time events, and switch position changes can be transmitted to the upper-level dispatch system, implementing the "four remote" functions. The default baud rate is 9600.

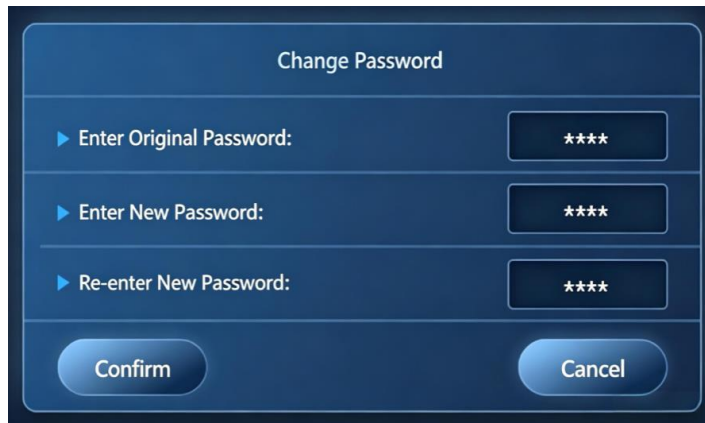

Users can modify the password through the password change function to ensure user security.

Chapter 6 Device Power-Up and Commissioning

6.1 Device Energization and Status Check

When the power is switched on, the normal status is that the LCD screen lights up and the touch screen operates normally

6.2 Parameter Setting

After the device is powered on, please set the parameters of the device according to the actual on-site conditions of the shunt capacitor bank. For the parameter setting method, refer to the descriptions in Chapter 5 above.

6.3 Commissioning Purpose

To verify the correctness of the wiring between the device's rear terminals and



RWCME-I Shunt Capacitor Online Early Warning and Protection Device

other secondary circuits, and to prevent incorrect wiring.

6.4 Commissioning Methods

1. Analog Input Interface Commissioning

Apply analog quantities (voltage, current, $\Delta \theta$) to the terminal block using a standard power source, and check whether the bus voltage, bus current, capacitor current, temperature, and calculated capacitor/reactor parameters displayed on the operation interface are consistent with the actual conditions.

Note: The PT must be disconnected before applying analog quantities to prevent feedback power to the primary side.

2. Binary Input Interface Commissioning

Actuate each switch sequentially to generate position changes, and check whether the corresponding switch status displayed on the operation interface changes correctly.

3. Binary Output Interface Commissioning

Manually test the output of each binary output relay contact in the factory commissioning window to confirm normal operation.

Note: All group switches shall perform both closing and opening operations.

4. Interlock, Alarm & Trip Commissioning

Taking the unbalanced voltage protection as an example: first set the protection parameters, then simulate the protection operating conditions respectively, and check whether the corresponding trip signal (pulse signal) and alarm signal (maintained signal) are output correctly.

Chapter 7 After-Sales Commitment

For any products purchased from our company, we hereby make the following product quality assurance commitments to users:

7.1 Product Quality Commitment

Manufacturing and testing of the products are supported by complete quality records and test data.

Strictly control all links, including raw material procurement and production processes, in accordance with CQC quality certification standards, ensuring every process is under quality control to guarantee product quality.

All delivered products undergo 100% inspection in strict accordance with testing procedures, ensuring a 99% first-pass inspection rate for finished products and a 99% pass rate for random inspections.

We sincerely invite users to conduct full-process and full-performance inspections of the products. Products will only be packed and shipped after user confirmation of acceptance.

7.2 Product Price Commitment

To ensure high reliability and advanced performance, the system uses high-quality



RWCME-I Shunt Capacitor Online Early Warning and Protection Device

domestic or international brand-name materials and components.

Under equal competitive conditions, our company sincerely offers the most favorable prices to users without compromising product technical performance or changing product components.

7.3 Delivery Schedule Commitment

Product delivery will follow user requirements as much as possible. For special requests requiring early completion, our company can arrange dedicated production and installation to meet user needs.

Upon delivery, our company will provide users with:

- ① User Manual
- ② Product and Packing List

7.4 After-Sales Service Commitment

- Service Philosophy: Fast, decisive, accurate, thorough, and comprehensive.
- Service Goal: Achieve user satisfaction through quality service.
- Service Efficiency: In the event of equipment failure, whether within or outside the warranty period, our maintenance personnel will arrive on-site and begin repairs within 24 hours of receiving notification.
- Service Principles: The product warranty period is 12 months. During the warranty period, repairs and replacements of damaged components caused by quality issues will be provided free of charge. For component damage outside the warranty period, replacement parts will be provided at cost price. For equipment damage caused by user factors, repairs and replacement parts will also be charged at cost price.