

A light gray silhouette of a world map is centered in the background of the image. The text 'ROCWELL ENERGY' is overlaid on the map.

ROCWELL ENERGY



CONTENTS

01 RW Energy Profile

02 Solution Architecture

03 High Level Proposal

04 RW Energy Power Cases

CONTENTS

CONTENTS

01 RW Energy Profile

02 Solution Architecture

03 High Level Proposal

04 RW Energy Power Cases

CONTENTS

Zhejiang Rockwell Energy Technology Co., Ltd. is an international enterprise specializing in the research, development and manufacturing of recloser controllers, power quality management, power monitoring systems and other high-end power equipment. In today's critical period of global energy transition and power system upgrading, the company has gathered a group of top talents in the fields of power engineering, automation control, software development, etc.,

who carry the enthusiasm and persistence for the power business, and are committed to overcoming the complex problems in the power system, and promoting the intelligent development of the power industry with innovative technology. Mission: To make global electricity smarter, more reliable and more efficient with innovative technology. Vision: To be the leader in global power intelligence.

Overseas Marketing Area

40 + Countries

Europe and America

Southeast Asia

South Asia

Middle East

Africa

Central Asia

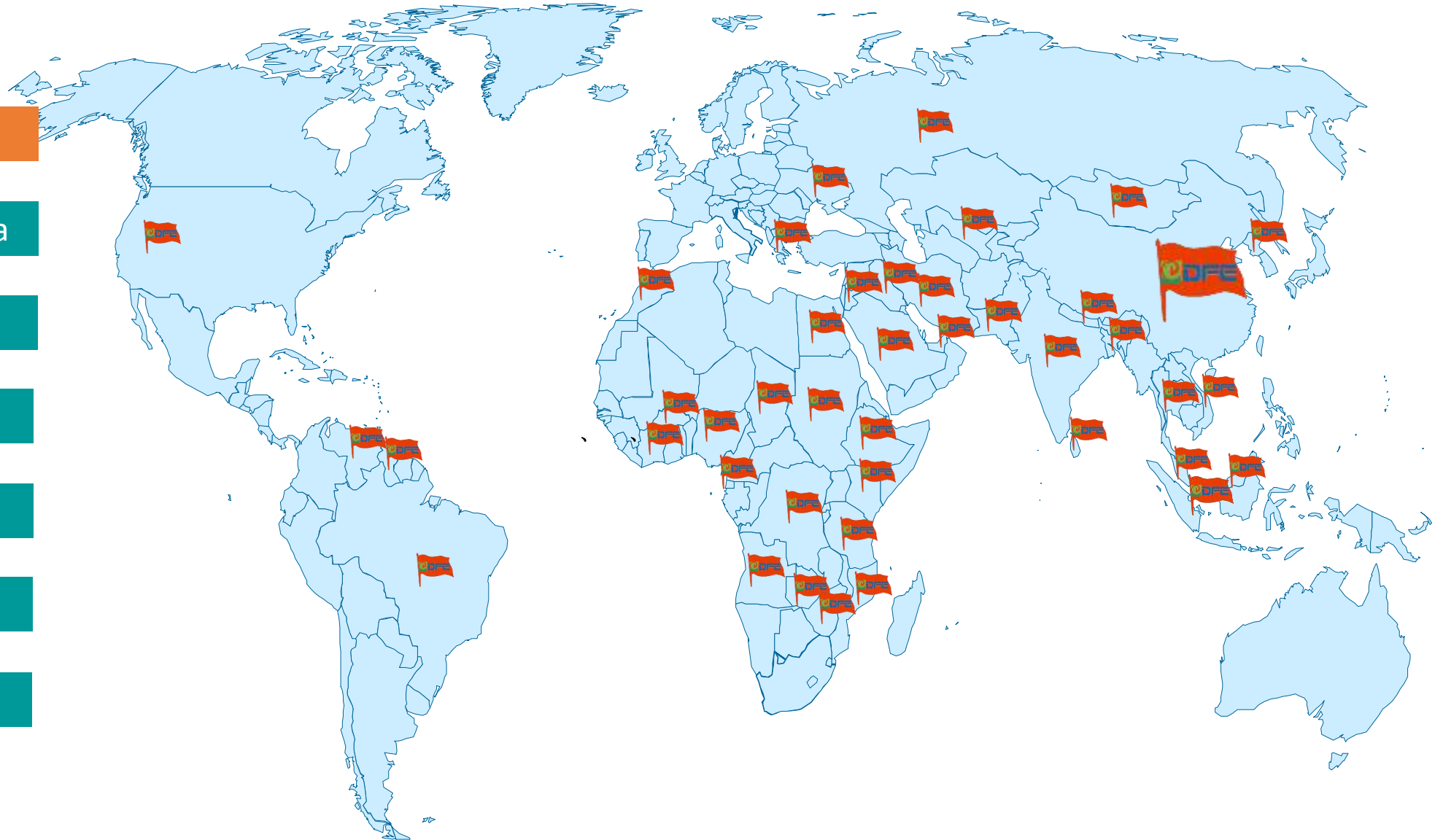

Business in Power Field

Power generation	IT-based application in power plant	<ul style="list-style-type: none"> ●Dispatch management and real-time dispatch system of power plant ●Operation management system of renewable energy in grid-connected operation mode ●Online monitoring system of energy consumption ●Firewall ●Real time isolation gateway ●Log auditing system ●Industrial intrusion detection system ●Operation & maintenance security auditing system
	Security protection	<ul style="list-style-type: none"> ●Network security monitoring device of the power monitoring system ●Data acquisition device of network security situational awareness of power monitoring system ●Host security monitoring software ●Substation security management system
	Renewable energy power generation	<ul style="list-style-type: none"> ●Renewable energy monitoring system ●Power forecasting system of PV generation ●Wind power forecasting system ●Automatic monitoring and control system of photovoltaic power station ●Electric monitoring and control system of station service power ●Step-up substation monitoring and control system in power plant ●Frequency and voltage emergency control device ●Fault disconnection device ●Spare Power Automatic Switching Apparatus ●Network security monitoring
Power transmission	Smart dispatching	<ul style="list-style-type: none"> ●Dispatching system of smart grid ●Online monitoring system of secondary equipment ●Intelligent alarm system ●Integrated power grid planning and verification ●Program-based operation ●Automatic generation control ●Automatic voltage control of ●Intelligent analysis and decision support ●Decision support of intelligent power recovery ●Load batch control ●Regional spare power automatic switching ●Automatic switching in/off of spare power ●Power grid operation control cabin ●New generation of elastic support platform ●Operation data cloud platform ●Dispatching operation data center ●Management and control of dispatching cloud data quality
	Smart substation	<ul style="list-style-type: none"> ●Automation system of smart substation ●Integrated automatic system of substation ●Transmission and control unit of fire information ●Network security monitoring ●Comprehensive monitoring system of the auxiliary equipment of smart substation ●Integrated monitoring platform of the auxiliary system of smart substation ●Smart inspection system of substation videos ●Metering system of smart substation
	Electric power market	<ul style="list-style-type: none"> ●Comprehensive application data platform of power enterprise ●Technical support system of "Two Rules"
	Intelligent operation & maintenance	<ul style="list-style-type: none"> ●Centralized monitoring system of auxiliary equipment ●Comprehensive processing system of power transformation information ●Intelligent inspection system of remote videos ●Unified monitoring platform of power grid videos (DF1510) ●Power and environment monitoring system (DF1520) ●Intelligent robot inspection system ●Intelligent bare conductor insulation solution ●Recognition technology solution based on artificial intelligence
Power distribution	Master station of power distribution	<ul style="list-style-type: none"> ●Power distribution and operation management system of new generation ●Power distribution IoT platform ●Failure self-recovery control of power distribution ●Comprehensive study and judgment of outage in power distribution ●Full resource collaborative-optimized dispatch of active distribution network ●Power distribution risk evaluation ●Optimization of power distribution operation mode ●Loop closing risk analysis ●Quality management & control of model and graph of power distribution
	Power distribution terminal	<ul style="list-style-type: none"> ●FRTU ●RTU ●Fault location system of feeder ●Fault passage indicator ●Fault passage indicator with fault recording ●Automatic testing apparatus of power distribution terminal ●Power loss module for the feeder terminal ●Power loss module for the station terminal
	Intelligent primary equipment	<ul style="list-style-type: none"> ●Primary and secondary packaged equipment ●Triangular distribution transformer ●Smart switch on automatic full set column ●Full set switch on column ●Gas-insulated ring main unit ●Green gas-insulated ring main unit ●Steel-clad movable-type A.C. metal-enclosed switchgear ●Solid-sealed polar pole vacuum breaker of steel-clad movable-type A.C. metal-enclosed switchgear ●Indoor metal-enclosed withdrawable switch cabinet ●AC low-voltage distribution cabinet ●Low-voltage distribution cabinet ●Power distribution cabinet ●Power supply cabinet ●Distribution box ●Smart distribution equipment cabin ●Smart box-type substation ●American style box transformer ●Joint box ●Nonmetal measuring tank ●Integral power system
Power utilization	Smart acquisition and management of power utilization information	<ul style="list-style-type: none"> ●Technical support system for power utilization dispatching ●Integrated system solution for electric energy acquisition and management ●Integrated platform for the acquisition and management of electric energy information ●Power utilization information acquisition terminal ●Electric energy measurement ●Smart electric energy meter series ●High voltage measurement
	Electric vehicle charging equipment	





Quality Assurance



Protocol Certificate



01 RW Energy Profile

02 Solution Architecture

03 High Level Proposal

04 RW Energy Power Cases

CONTENTS

CONTENTS



Solution Architecture

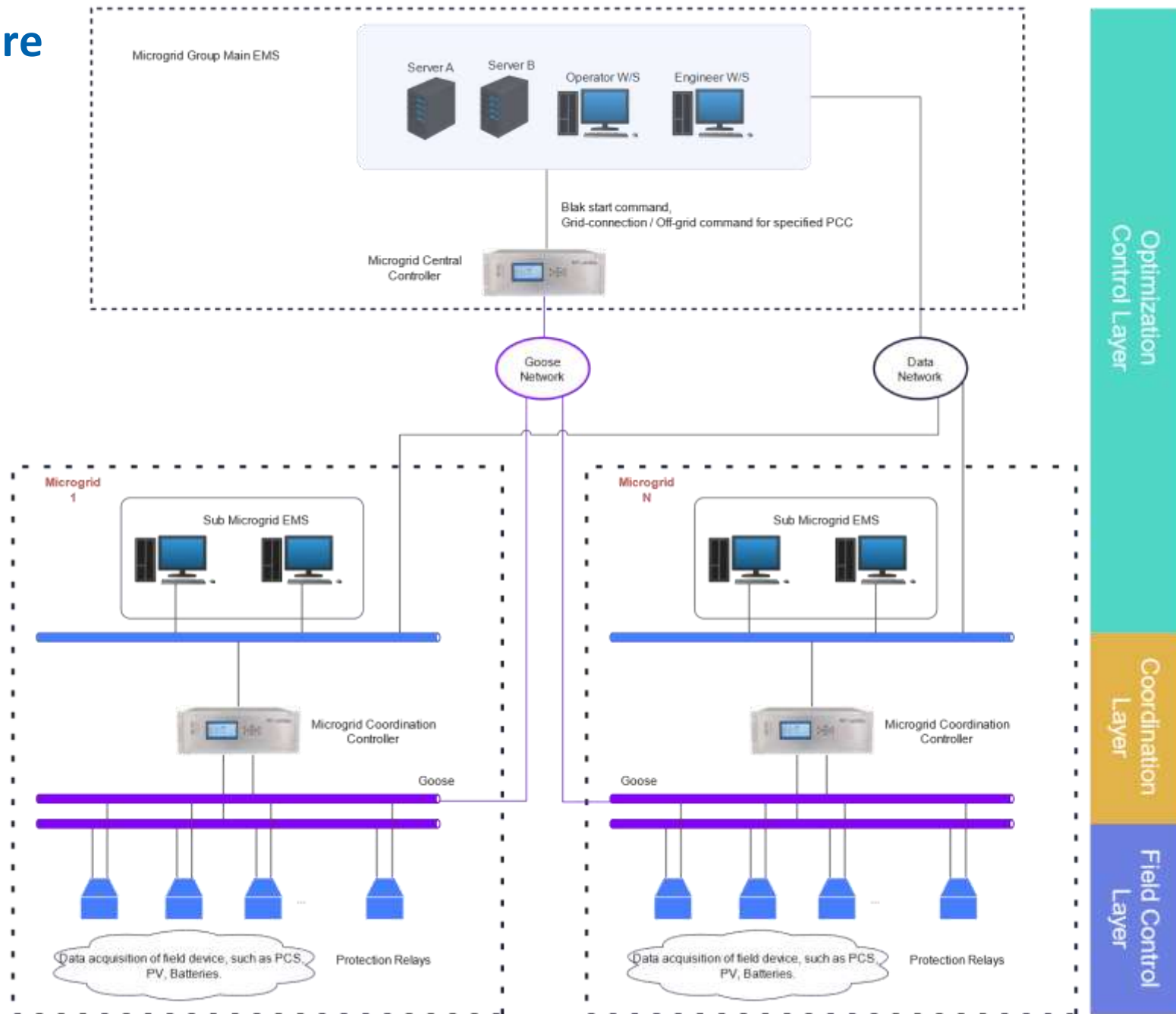

01 RW Energy Profile

02 Solution Architecture

03 High Level Proposal

04 RW Energy Power Cases

CONTENTS

CONTENTS

VSG based grid-forming PCS

Virtual Synchronous Generator (VSG) technology is a technology that simulates the electromechanical transient characteristics of the synchronous unit, that is, the electromechanical transient equation of the synchronous motor is used in the control part of the power electronic converter, so that the converter has the inertia, damping, frequency and voltage regulation and other external characteristics of the synchronous unit, which solves the problem of the lack of inertia and damping characteristics of the converter under the traditional droop control, and can improve the frequency and voltage stability of the new type power system.

- The control system is composed of VSG algorithm, virtual impedance, voltage and current double closed-loop control and SVPWM modulation.
- VSG algorithm simulates the characteristics of inertia, damping, and primary frequency regulation of the synchronous generator, and provides the output instructions of frequency and voltage for PCS.
- The virtual impedance strategy controls the PCS output to be biased towards inductance, ensuring the the strong correlation between active/frequency and reactive/voltage.
- The voltage and current double closed-loop control realizes the voltage following and stable control of the PCS, making the PCS present the characteristics of voltage source.
- Space Vector Pulse Width Modulation (SVPWM) improves the DC voltage utilization rate and DC capacitor voltage balance ability of PCS.

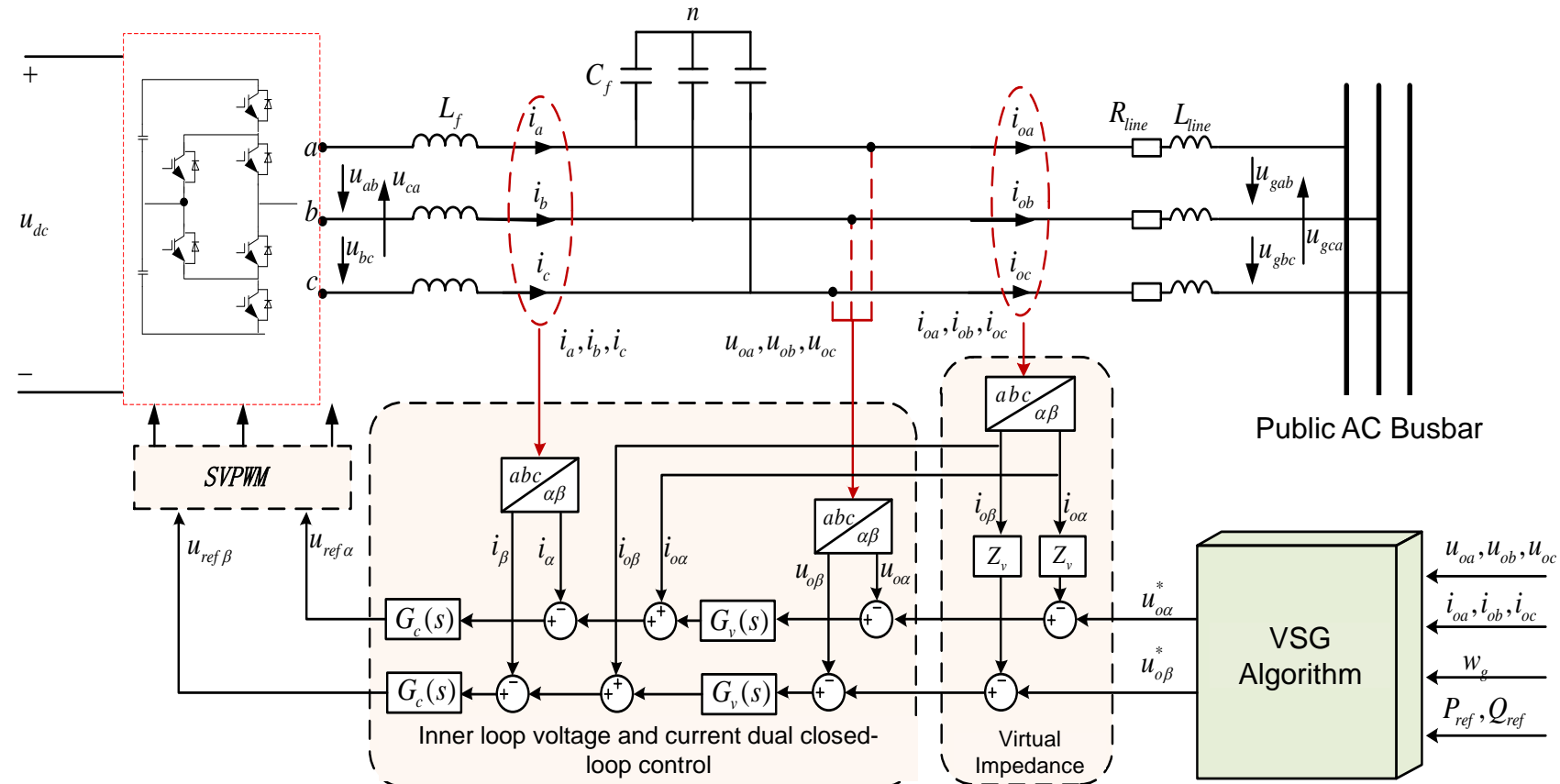

High Level Proposal – Grid-forming BESS and It's Wide-area Collaborative Control (2)

Grid-forming PCS Control Algorithm

Virtual Rotor Equations:

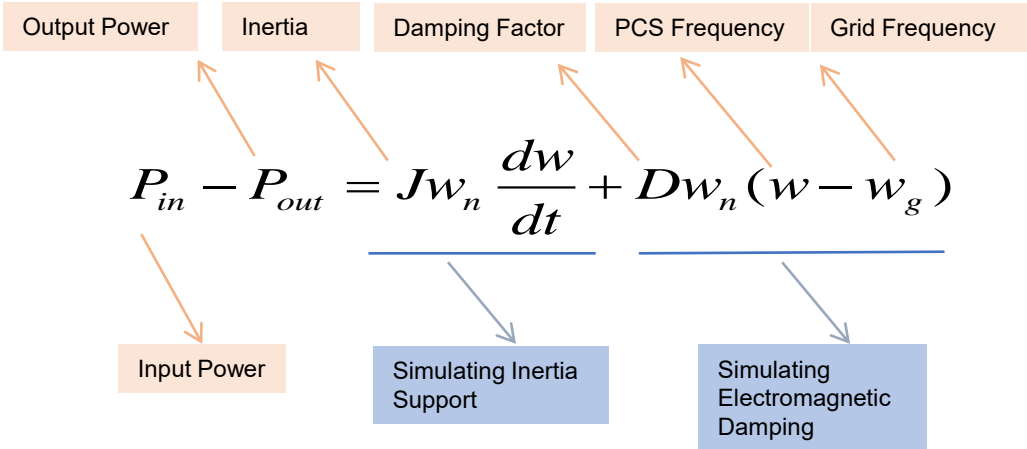

Virtual speed governor simulates primary frequency regulation:

Power Command

$$P_{in} = P_{ref} + k_w (\omega_n - \omega)$$

Frequency Regulation Factor



$$P_{ref} + k_w (\omega_n - \omega) - P_{out} = J\omega_n \frac{d\omega}{dt} + D\omega_n (\omega - \omega_g)$$

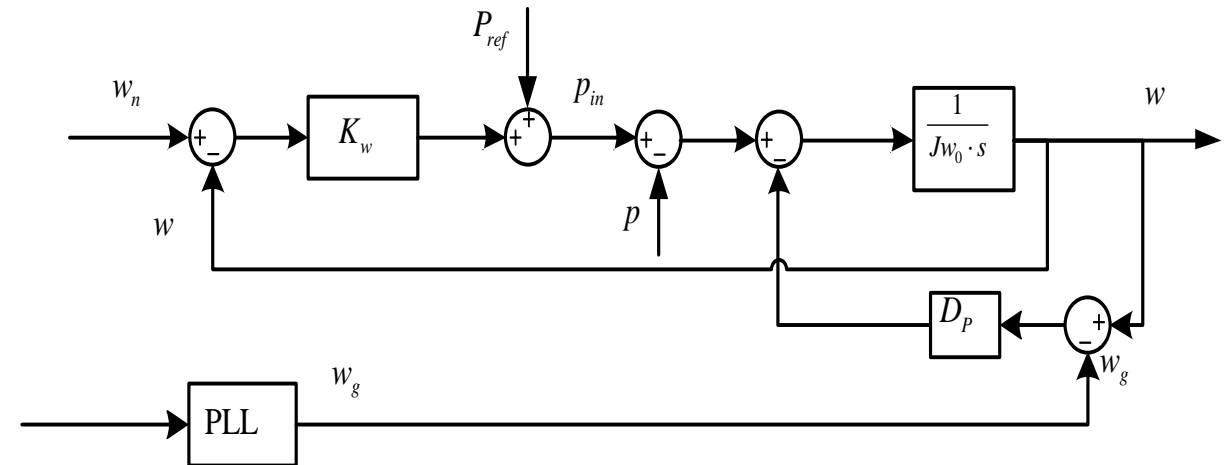

Grid-forming PCS Wide-area Collaborative Control Scenarios

Inertia Response Collaborative Control

- The inertia time constant value in the VSG control of each PCS in BESS is small to improve the power response speed of BESS, and BESS provides insufficient inertia support for the frequency regulation.
- When any PCS or microgrid coordination controller in a wide area detects that the system frequency change rate reaches the set value, it sends commands to increase the inertia time constant and regulate the damping power through the Goose network, and each PCS receives the commands and responds quickly to suppress the rapid change of system frequency to achieve the purpose of cooperative control.

Frequency / Voltage Regulation Collaborative Control

- Frequency / Voltage regulation control: The wide-area distributed BESS unit quickly exchange their respective battery SOC and present output power, and the coordination controller calculates the active power and reactive power for each PCS and flexible direct interconnection to achieve the purpose of collaborative control.
- Black start: Each BESS unit distributed in wide area enter the start-up procedure according to the pre-specified start-up sequence and start-up voltage, and the start-up voltage is set to 20% of the rated voltage. After the first BESS unit starts, the subsequent units start one by one and connect to the grid, and when all units are connected to the grid, the grid-connected system is controlled by the microgrid central controller to synchronously boost the voltage to reach the rated voltage.

Microgrid Coordination Control

Through real-time monitoring and optimization control of the power source, grid, load, BESS and charging load of the microgrid, the microgrid coordination controller meets the needs of comprehensive microgrid operation monitoring, intelligent safety analysis, forward-looking regulation and control, and dynamic panoramic analysis, and completes the flexible interaction and economic optimization operation among wind, PV, BESS, charging and load resources under different targets, so as to maximize energy efficiency, economic benefit and environmental benefit. The operating mode is shown in the figure below.

Grid-connection Operation Control: Each distributed generation device in the microgrid system adjusts itself according to field information to realize plug-and-play at the equipment level, and actively participates in the voltage and frequency support of the power grid.

Off-grid Operation Control: When the microgrid is off grid, the frequency and voltage emergency control are used to balance the power demand in the microgrid by controlling the BESS output, rapid load shedding and decoupling DG, so that the frequency and voltage can be restored to the allowable operating range.

Microgrid Operation Mode Switching: When the microgrid is switched from grid-connection to off-grid, the coordination controller quickly detects the island state, opens the PCC circuit breaker and sends the island signal to BESS and other distributed power sources, and each sub-area is continuously powered by the sub-microgrid, and the BESS is used as the VF node to support the voltage frequency of the sub-microgrid. The microgrid coordination controller provides automatic simultaneous closing function to realize the safe grid connection of the microgrid.

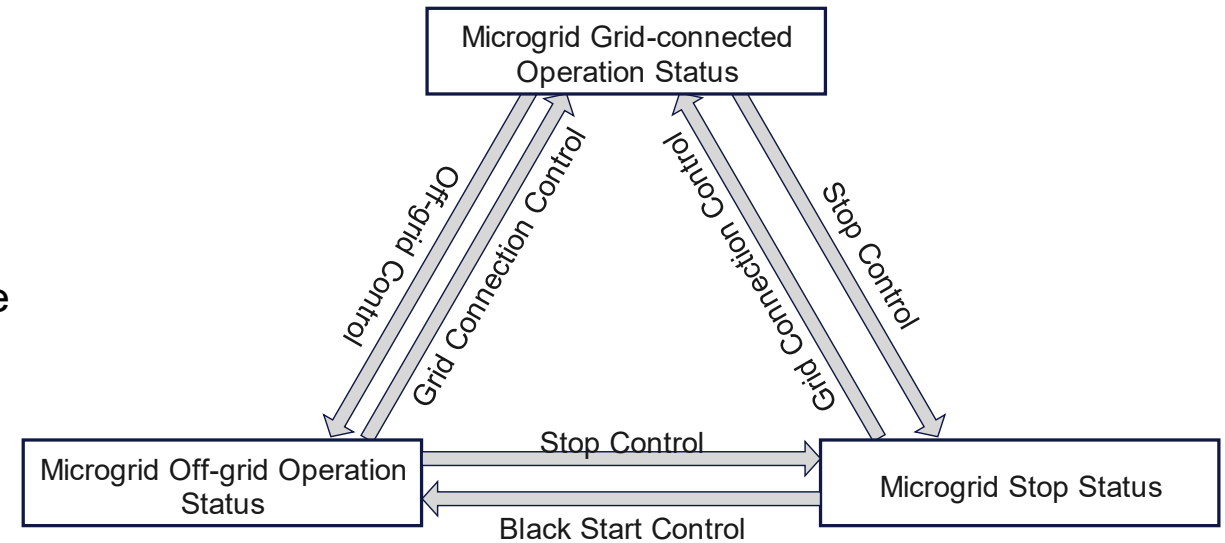

High Level Proposal – Microgrid Operation and Control (2)

Control Strategies

By dynamically adjusting the power of the BESS and DG to maintain the power within a predetermined range, it makes microgrid become a controllable source/load.

It implements dynamic optimization and coordination control of resources in the network, so as to realize the local consumption of RES, the complementary advantages of power source, grid, load and storage, and the integrated and coordinated operation of resources within the microgrid.

Island detection: It monitors the PCC circuit breaker, current, power, signal status and microgrid key point data, monitors and detects the grid-connection and off-grid status of the microgrid in real time, and builds a topology model as the basis for the grid-connection and off-grid status, switching and strategies optimization.

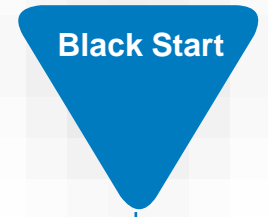
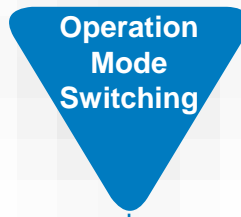
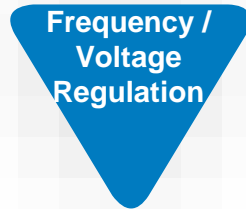

It has the ability of primary frequency regulation, inertia response and rapid voltage regulation, which can realize the rapid response support of the microgrid and maintain the stability of voltage and frequency.

Grid-connection to Off-grid: The coordination controller quickly detects the island state, opens the PCC circuit breaker and sends the island signal to BESS and other distributed power sources, and each sub-area is continuously powered by the sub-microgrid, and the BESS is used as the VF node to support the voltage frequency of the sub-microgrid.
Off-grid to Grid-connection: The microgrid coordination controller provides automatic simultaneous closing function to realize the safe grid connection of the microgrid.

Using the controllable power sources in the microgrid and cooperating with the EMS system, it identifies topology in real time, controls the mode of the microgrid power supply and controls the mode switching when different black start areas being in parallel.

Microgrid EMS Overall Architecture

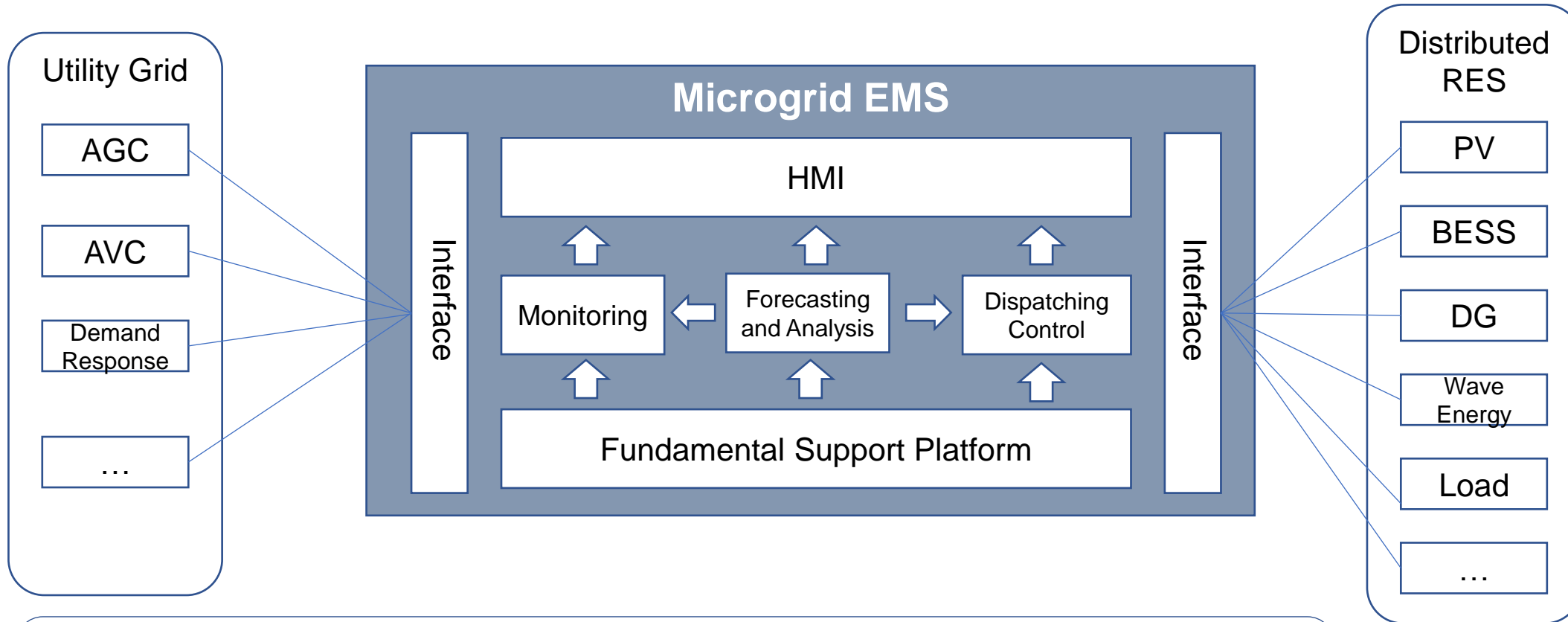

- **Improve the resilience of microgrids, improve situational awareness and risk response capabilities**
- **Improve the level of collaborative interaction with utility power grid**

Main Functions 1 – Microgrid State Monitoring and Analysis & Forecasting

Microgrid State Monitoring

- Space Dimension Based Distributed Monitoring
 - Geographical distribution
 - Topological distribution
- Time Dimension Based Operation State Monitoring
 - Historical State
 - Real-time State
 - Trend State
- Intelligent Alarm
 - Single device abnormal state alarm
 - System comprehensively abnormal state alarm
- Data Visualization
- WEB Publishing and Remote Monitoring

Microgrid Analysis & Forecasting

- Distributed Generation Forecasting
 - AI methods are used to achieve high-precision forecasting of distributed generation.
 - Support short-term and ultra-short-term forecasting.
- Granular Load Forecasting
 - AI methods are used to achieve granular load forecasting.
 - Support short-term and ultra-short-term forecasting.
 - The impact of special events, holidays, different types of load characteristics, etc., can be considered.
- Power Flow Calculation
 - Support various topology structures.
 - Support active distribution network with a high proportion of distributed generation.
 - Support real-time mode and study mode. Various control operations can be simulated in the study mode.
- Time Series Simulation and Situation Analysis
 - The parallel computing technology is used to realize efficient time series simulation, which provides a basis for accurately evaluating the operation situation of the microgrid.

Main Functions 2.1 – Microgrid Dispatching Control

Dispatching Plan

■ Grid-connected Mode

- According to the power generation and load forecasting data, the exchange power between the microgrid and the utility power grid, and the strategies of power generation of different power sources / load regulation / BESS charging and discharging are reasonably determined, so as to **realize the collaborative optimization dispatching of the main microgrid** and improve the **RES consumption level**. The determined regulation plan is directly issued to or is through the microgrid coordination controller to each distributed resource for execution by setting points.
- **Planned off grid**. It is to control the power of tie-line between microgrid and utility grid to be close to 0 through the coordination and optimization of power source, grid, load and BESS, which creates conditions for the planned off-grid operation.

■ Off-grid Mode

- It utilizes the real-time collected data, as well as the power generation and load forecasting data in the microgrid, optimally dispatches different power sources, loads, and BESS in real time, and realizes the **coordinated control of source and load** as well as the **dynamic balance of power in the microgrid** under the premise of ensuring the safety and stability of the microgrid.

Main Functions 2.2 – Microgrid Dispatching Control

Active Power / Frequency Control

■ Grid-connected Mode

- **Response to the AGC control target value of the main grid:** It decomposes the target value, issues them to the microgrid coordination controller, and then sends them to various distributed adjustable resources to realize the active power / frequency control, and makes the exchange power of tie-line between microgrid and utility grid meet the requirements of the upper-level dispatching.
- **Response to the demand-side response of the upper-level dispatching:** It regulates the power generation and load of the microgrid to meet the peak shaving needs of the upper-level dispatching.

■ Off-grid Mode

- **Real-time AGC control:** It monitors microgrid's frequency in real time, and gives regulation strategies for distributed generation, BESS, etc., coordinating with microgrid coordination controller, to maintain the stable frequency of each microgrid;
- **BESS reserve support:** According to the requirements of the stable operation of the microgrid, it maintains the necessary reserve regulation capacity through the regulation and control of various distributed generations and BESS.

Main Functions 2.3 – Microgrid Dispatching Control

Reactive Power / Voltage Control

■ Grid-connected Mode

- **Receiving upper-level dispatching AVC commands**, it collaborates with microgrid coordination controller, and realizes the AVC based on layers and zones, to ensure the voltage quality of requirements.
- **AVC of microgrid itself**: It optimizes the distribution of reactive power flow and reduces the line loss of the power grid.

■ Off-grid Mode

- **Microgrid AVC control**: It monitors the voltage and power factor of the microgrid monitoring point in real time, coordinates with the microgrid coordination controller, and gives the adjustment strategy of distributed generations, BESS, etc., to ensure that the voltage quality and power factor of each monitoring point meet the requirements.
- Under the condition of not affecting the consumption of distributed generation, it locally balances the reactive power as much as possible to reduce the line loss of the microgrid.

CONTENTS

01 RW Energy Profile

02 Solution Architecture

03 High Level Pr

04 RW Energy Power Cases

CONTENTS

1) Inner Mongolia Alxa Youqi 150,000 kW Generation Side BESS Frequency Regulation Project

45MW/90MWh BESS in 150,000 kW Wind power plants of Huadian Group in Neimeng Province is a project integrates EMS and PMS for power side energy storage to participate in grid frequency regulation control. It intelligently controls 38 BESS containers for charge and discharge optimization control, responding to grid AGC/AVC and frequency regulation.

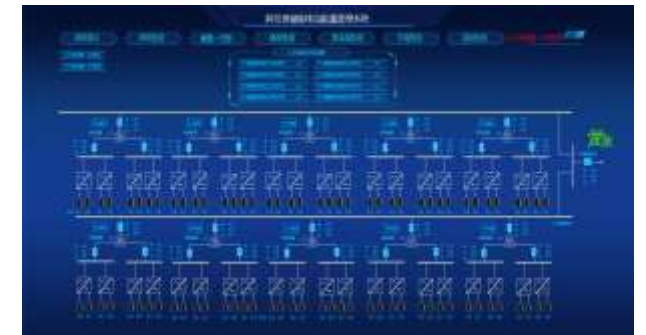
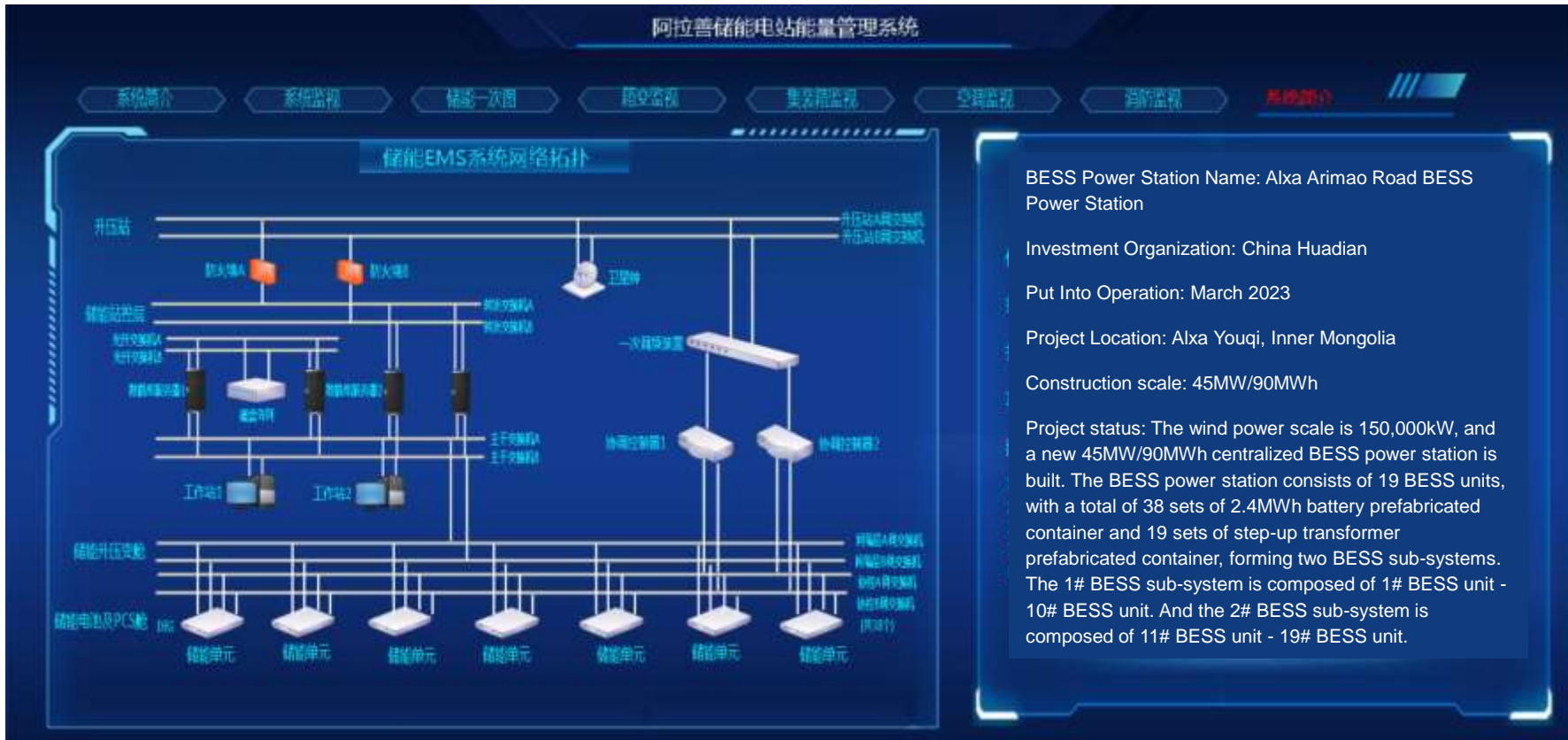

2) Dongying Phase III Distributed PV BESS EPC Project

A total of 11 large-scale factories' roofs of Dongying Sailun Group (tires manufacturer) located in Guangrao district and Kenli county have been used to build PVs, with a total installed capacity of 41.76MW and an average annual power generation of more than 50 million kWh, equivalent to a reduction of 46,700 tons of carbon dioxide emissions. It is the largest distributed PVs with BESS project in Shandong Province. The total investment of the project is 160 million RMB, equipped with a 2.6MW/5.2MWh BESS, and 1375kW liquid-cooled BESS PCS adopted.

RW Energy is the EPC contractor.



3) Shanxi Yangquan Majiaping Park Multi-element Smart Microgrid

Based on the existing power resources of Majiaping substation, rooftop PVs of the power supply center in the mining area, charging stations and other facilities, integrating and applying innovative technologies such as energy routers, modular BESS, V2G bidirectional charging and discharging, carbon monitoring and carbon assessment, etc., an efficient and smart energy management and control system with electricity and carbon working together is built to realize the global energy dispatch of the microgrid in the park.

The core equipment of the energy router includes 2 sets of 250kW flexible interconnection equipment, 1 flexible interconnection coordination controller, 1 combiner cabinet with 12 nos of 750V DC outgoing lines, 1 network switch and Lora gateways, etc.

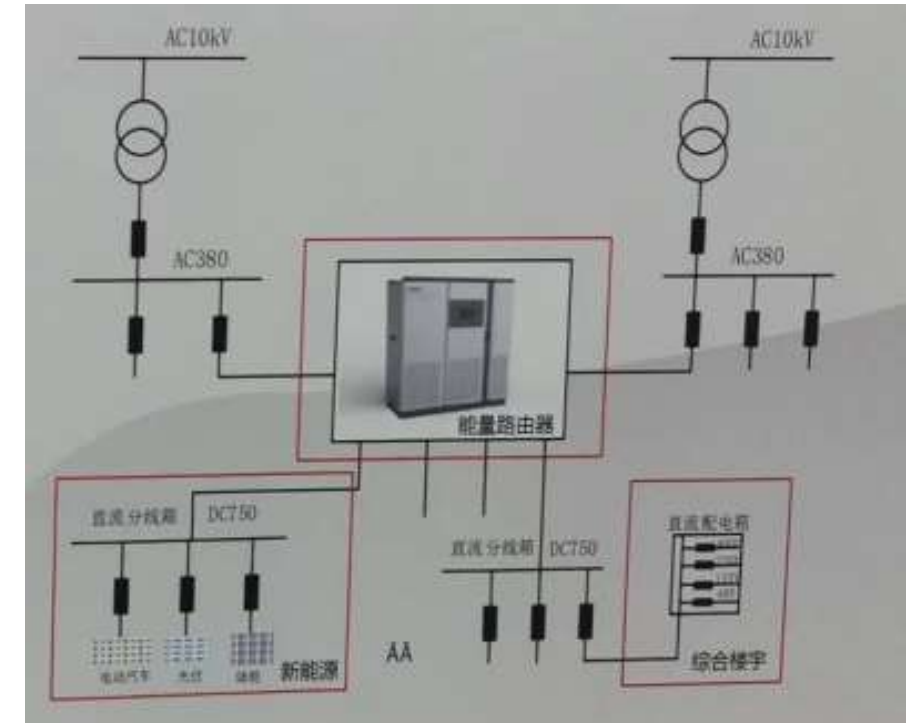



Welcome to explore RW Energy more!